

PUB. SEWER STATUS VERIFIED BY \_\_\_\_\_

ISSUE DATE: 05/07/08

P 528929

APPROVAL DATE: 5/30/08 *Logged Into Permit Manager  
Tax ID # 04338529*

A UPGRADE

# PERMIT

## ON-SITE SEWAGE DISPOSAL SYSTEM HOWARD COUNTY HEALTH DEPARTMENT BUREAU OF ENVIRONMENTAL HEALTH

Hatfields Equipment IS PERMITTED TO INSTALL  ALTER

ADDRESS: PO Box 519, Annapolis Junction PHONE NUMBER: 301-854-6172

SUBDIVISION: Ritz Estates LOT NUMBER: 8

ADDRESS: 16985 Moss Meadow Way PROPERTY OWNER: J Martin & M Contreras

SEPTIC TANK CAPACITY (GALLONS): 1500

PUMP CHAMBER CAPACITY (GALLONS): N/A

NUMBER OF BEDROOMS: 4

SQUARE FEET PER BEDROOM: \_\_\_\_\_

LINEAR FEET OF TRENCH REQUIRED: 207

*Trenches 2' Wide  
Inlet 3.5', Bottom 7.5'*

TRENCHES:	Trench to be 3.0 feet wide. Inlet 3.0 feet below original grade. Bottom maximum depth 6.0 feet below original grade. Effective area begins at 5.0 feet below original grade. 3.0 feet of stone below distribution pipe.
LOCATION:	
PURPOSE:	Advanced pre-treatment is required for the septic system due to SDA being located <200' from down gradient wells.

PLANS APPROVED: Sara Sappington DATE: 05/09/08

- NOTE: PERMIT VOID AFTER 2 YEARS
- NOTE: CONTRACTOR RESPONSIBLE FOR SCHEDULING A PRE-CONSTRUCTION INSPECTION FOR ALL INSTALLATIONS
- NOTE: WATERTIGHT SEPTIC TANKS REQUIRED
- NOTE: ALL PARTS OF SEPTIC SYSTEM SHALL BE 100 FEET FROM ANY WATER WELL
- NOTE: MANHOLE RISERS REQUIRED ON ALL SEPTIC TANKS AND PUMP CHAMBERS

**NEITHER THE HOWARD COUNTY COUNCIL OR THE HEALTH DEPARTMENT IS RESPONSIBLE FOR THE SUCCESSFUL OPERATION OF ANY SYSTEM PERMITTEE RESPONSIBLE FOR OBTAINING FINAL APPROVAL ON THIS PERMIT CALL 410-313-2640 FOR INSPECTION OF SEPTIC SYSTEM**

HO-73-3459

NOT TO SCALE

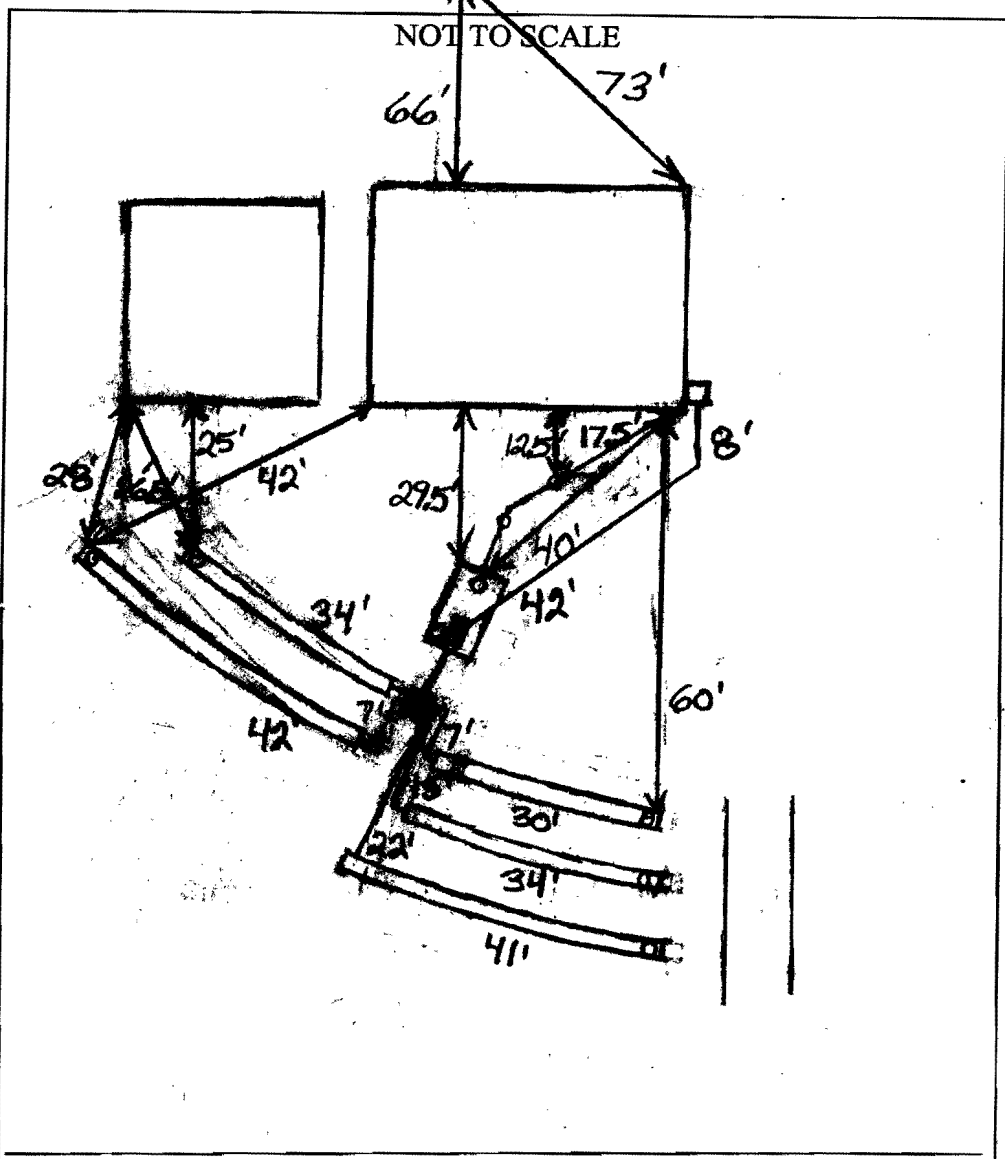

TRENCH/DRAINFIELD DATA		
WIDTH	INLET	BOTTOM
2'	3.5'	7'
NUMBER OF TRENCHES		5
TOTAL LENGTH		181'
ABSORPTION AREA		362x2
DISTRIBUTION BOX LEVEL		Levelers
DISTRIBUTION BOX BAFFLE		Yes
DISTRIBUTION BOX PORT		Yes

SEPTIC TANK DATA	
SEPTIC TANK 1 LEVEL	Yes
CAPACITY	1500 GAL
SEAM LOC	Top
TANK LID DEPTH	15-25'
BAFFLES	Front + 2 Middle
BAFFLE FILTER	No
MANHOLE LOC	Middle
6" PORT LOC	Front + Middle
WATERTIGHT TEST	No
SEPTIC TANK 2 LEVEL	N/A
CAPACITY	_____ GAL
SEAM LOC	_____
TANK LID DEPTH	_____
BAFFLES	_____
BAFFLE FILTER	_____
MANHOLE LOC	_____
6" PORT LOC	_____
WATERTIGHT TEST	_____

Moss Meadow Way

PRE-CONSTRUCTION 5/19/08 Layout done. (BB)

INSTALLATION 5/29/08 Tank set. Three trenches done. House connection made. (BB) 5/30/08 System finished. Firewire to inspect next week. (BB)

FINAL INSPECTOR B Baber

DATE OF APPROVAL 5/30/08

SELLER: JOHN J. STAMERRO

LEGAL DESCRIPTION:

Lot 8, Block "B", RITZ ESTATES as recorded in Plat No. 3679, one of the Plat Records of Howard County, Maryland, also locally known as 16985 Moss Meadow Way, Mt. Airy, Maryland.

HOUSE LOCATION SURVEY:

Lot 8, Block "B", RITZ ESTATES  
Plat No. 3679, Howard County,  
Maryland Plat Records

NOTE: This plat is not to be relied upon for the establishment or location of fences, garages, buildings, or other existing or future improvements.

BUILDING LINE AND/OR FLOOD ZONE INFORMATION IS TAKEN FROM AVAILABLE SOURCES AND SUBJECT TO INTERPRETATION OF ORIGINATOR



*Breezeway  
5x32*

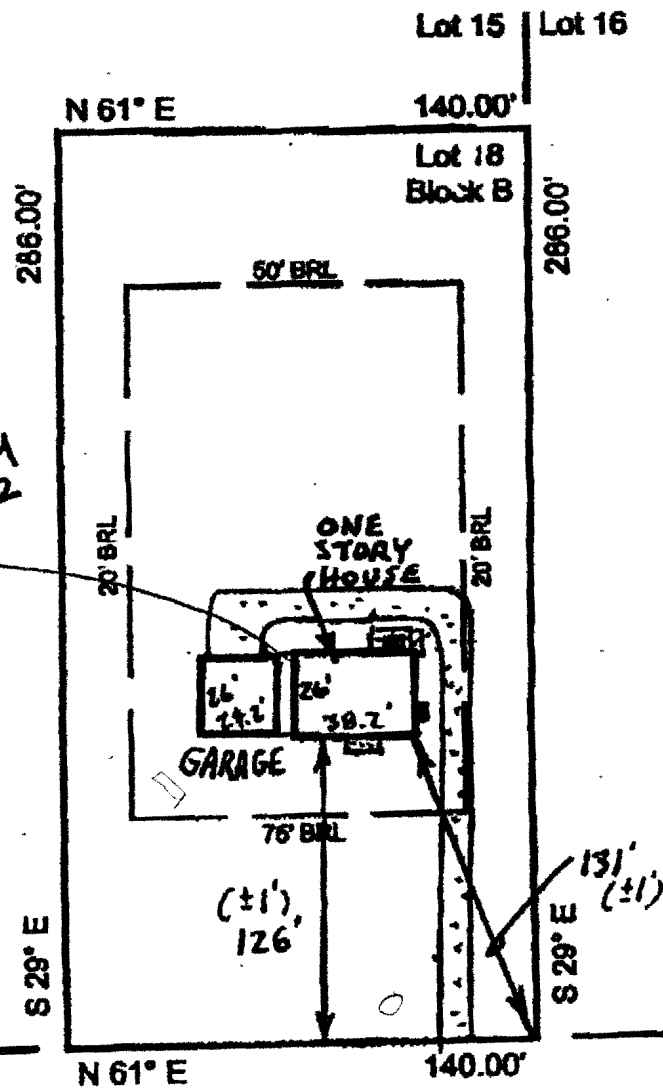

1" = 60'

# 16985 Moss Meadow Way

NOTE: This location is for title purposes only and not to be used for determining property lines. Property corner markers are NOT guaranteed by this location.

MDE**MARYLAND DEPARTMENT OF THE ENVIRONMENT**  
1800 Washington Boulevard • Baltimore MD 21230  
410-537-3000 • 1-800-633-6101Martin O'Malley  
GovernorAnthony G. Brown  
Lieutenant GovernorShari T. Wilson  
SecretaryRobert M. Summers, Ph.D.  
Deputy Secretary

March 6, 2008

Martin & Minerva Contreras  
16985 Moss Meadow Way  
Mt. Airy, MD 21771

RE: Tax Map 7, Block 03, Parcel 481, Lot 8

Dear Mr. &amp; Mrs. Contreras:

Your bid package for the Bay Restoration Fund (BRF) Onsite Sewage Disposal System (OSDS) Program has been approved for the use of funds totaling not more than \$13,325. The accepted bid amount is for the installation of a BioMicrobics Model .5 for your property located at 16985 Moss Meadow Way, Mt. Airy, MD and shown on Tax Map 7, Parcel 481, Lot 8. You may choose to deviate from the selected unit, however the grant award for acceptable reimbursable expenses may not exceed \$13,325. All grants awarded through the Maryland Department of the Environment (MDE) are reimbursable. This means that all work done prior to this letter cannot be considered for reimbursement. In order to be eligible for reimbursement you must sign and record a copy in the land records of Howard County the Agreement and Easement for Installation of Best Available Technology Systems with Bay Restoration Funds. You must provide MDE with the following:

- The contractor's invoice. This invoice should include everything quoted in the bid. All expenditures greater than the bid amount will not be covered.
- A copy of the installation inspection performed by the Howard County Environmental Health program.
- A signed statement from the BAT Manufacturer that the unit was installed to their specific installation instructions.
- A signed statement that all work completed has met your satisfaction.
- A completed State Grant or Loan Payment Disbursement Request Form
- A copy of the Agreement and Easement for Installation of Best Available Technology Systems with Bay Restoration that shows that it has been recorded in the land records of Howard County.

All submitted documentation would be reviewed for compliance. Once all documentation is submitted, you will receive a payment directly from the State Comptroller's office.

Mr. & Mrs. Martin Contreras  
Page Two

The Maryland Department of the Environment thanks you for participating in this important program. If you have any further questions, please feel free to contact me at 410-537-3678 or 800-633-6101 ext 3678 or by email at [jboris@mde.state.md.us](mailto:jboris@mde.state.md.us).

Sincerely,

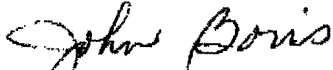

John A. Boris, Jr., R.S.  
Bay Restoration Fund Project Manager

Enclosure

cc: Jay Prager  
Howard County Health Department  
Jag Khuman, WQFA



# MARYLAND DEPARTMENT OF THE ENVIRONMENT

1800 Washington Boulevard • Baltimore MD 21230

410-537-3000 • 1-800-633-6101

Martin O'Malley  
Governor

Shari T. Wilson  
Secretary

Anthony G. Brown  
Lieutenant Governor

Robert M. Summers, Ph.D.  
Deputy Secretary

November 14, 2007

Martin & Minerva Contreras  
16985 Moss Meadow Way  
Mount Airy, MD 21771

RE: Tax Map 7, Block 3, Parcel 481, Lot 8

Dear Mr. & Mrs. Contreras:

Thank you for completing a pre-application for the Bay Restoration Fund (BRF) Onsite Sewage Disposal System (OSDS) Program. The pre-application submitted is for your property located at 16985 Moss Meadow Way, City Mount Airy, and shown on Tax Map 7, Parcel 481. A review of the pre-application indicates a high priority for funding. This letter is to notify you of preliminary approval for funding from the BRF for the installation of best available technology (BAT) for removing nitrogen as part of your on-site sewage disposal system.

This notification letter is intended to assist you through the process of obtaining proper BAT installation bids and invoicing procedures to obtain funding from the BRF. Please read this document carefully and follow instructions accordingly. The following sections outline the requirements necessary for proceeding with the project.

### Submission of Bids

Three bids must be submitted to MDE for review. If you are unable to obtain three bids you must submit to MDE a written record of your attempts to obtain a minimum of three bids. Bids must include the following:

- Notice that the installation will not be considered complete until the manufacturer or manufacturer's designee provides notice that the job has been satisfactorily completed. A manufacturer certified contractor might also serve as the manufacturer designee. The installer, whether they are a manufacturer representative or one chosen by the property owner, must submit an installation quote with each bid or the bid will be considered incomplete.
- An agreement for a minimum of five years operation and maintenance by a manufacturer approved service provider.
- Manufacturers must have an approved sampling protocol on file at MDE.
- Bids must be itemized. The bid is to include the cost of the unit and the installation cost of the unit. Only the components and labor (including electrical connections) directly related to upgrading an onsite sewage disposal system to the best available technology for removing nitrogen are eligible for funding.



- Manufacturers should respond to your request for bids within 14 days. After 14 days from your request for bids, you may submit to MDE the bids received and a list consisting of the manufacturers and manufacturers contact that did not respond to your request for a bid.
- The maximum number of BAT system installs an installer may be bid on is two. After 14 days from your request for installation bids, you may submit to MDE the bids received and a list consisting of the installers contacted that did not respond to your request for bid. At your request, MDE can provide you a list of installers that have participated in the program.

The following manufacturers have undergone MDE review and are eligible for BRF grants:

**Aquapoint, Inc. (Bioclere™ Model) [www.aquapoint.com](http://www.aquapoint.com)**

Contact: Robbie Tippet (240) 298-7572 [rtipp4@aol.com](mailto:rtipp4@aol.com)  
Sam Seymour (585) 473-3300 [sseymour@aquapoint.com](mailto:sseymour@aquapoint.com)

**Bio-Concepts, Inc. (ReCip® RTS) [www.bioconceptsinc.com](http://www.bioconceptsinc.com)**

Contact: Al Privette (252) 229-7040 [alprivette@coastal.net](mailto:alprivette@coastal.net)

**Bio-Microbics, Inc. (MicroFAST® & RetroFAST®) [www.biomicrobics.com](http://www.biomicrobics.com)**

Contact: Freemire & Associates (410) 768-8500 [www.freemire.com](http://www.freemire.com)

**F.R. Mahony & Associates, Inc. (Amphidrome™ Model) [www.frmahony.com](http://www.frmahony.com)**

Contact: David Kershner (610) 351-0963 [d.kershner@ketllc.com](mailto:d.kershner@ketllc.com)

**Hoot Aerobic Systems, Inc. (H-Series Hoot and Hoot BNR) [www.hootsystems.com](http://www.hootsystems.com)**

Contact: Nancy Mayer (410) 796-1434 [mayerbro@connext.net](mailto:mayerbro@connext.net)

**Lombardo Associates, Inc (Nitrex Systems) [www.lombardoassociates.com](http://www.lombardoassociates.com)**

Contact: Pio Lombardo (617) 964-2924 [pio@lombardoassociates.com](mailto:pio@lombardoassociates.com)

**Norweco, Inc. (Singular Model TNT System) [www.norweco.com](http://www.norweco.com)**

Contact: Eastern Shore, Randy Clark (800) 773-9128 [ranjodan@yahoo.com](mailto:ranjodan@yahoo.com)  
Western Shore, Jeff Earnshaw (301) 274-3772

**SeptiTech, Inc. (SeptiTech® Model) [www.septitech.com](http://www.septitech.com)**

Contact: Bruce Melton (410) 878-2952 [rbmelton@progressiveseptic.com](mailto:rbmelton@progressiveseptic.com)  
Western MD, Scott Everhart (304) 676-3823 [www.cseenterprises.net](http://www.cseenterprises.net)

**Waterloo BioFilter Systems, Inc. (Waterloo Biofilter Model) [www.waterloo-biofilter.com](http://www.waterloo-biofilter.com)**

Contact: Waterloo, Ontario, Canada (519) 856-0757

Conditions of Financial Assistance

By reading and signing this form, you agree to the limitations and conditions set forth in this document. This form must be returned with your submission of bids. Your bid submission will be considered incomplete if this form does not accompany it.

Award of Grant

- MDE will review the bids. The grant award will be obligated based on the lowest acceptable bid, however the applicant may select a higher acceptable bid.
- The applicant will be notified by MDE as to the amount of the grant obligation.
- For awards greater than \$25,000 MDE must present a proposal to the Board Public Works for approval.
- No change orders will be accepted by MDE.
- The award amount is available for reimbursement within 6 months of Department signature on the Agreement and Easement document. Upon request of the applicant, the original 6-month period may be extended at the discretion of the Department.

Agreement and Easement

An Agreement and Easement must be completed, signed by all parties and recorded in the Land Records of Howard County Maryland. A draft copy of the Agreement and Easement is provided to you in this letter for your review. A completed Agreement will be provided to you after bids are submitted to MDE when you are notified of the grant approval amount. The purpose of this Agreement is to accomplish the following:

- To establish your voluntary participation in this program.
- To ensure that a minimum of five years operation and maintenance is performed by an approved provider (included in the upfront cost of the system).
- Allows access for State, County and the Manufacturer designee's to inspect and collect samples from the system.
- Establishes the amount of the grant award.

Local Permitting Requirements

- All required local permits must be obtained.
- Permit fees are not eligible for BRF funding.
- Contact Howard County Health Department for more information.

Submission of Invoice

- Upon completion of the job, owner submits an invoice to MDE.
- The invoice must include the following;
  - Notice that the job was completed to the satisfaction of the owner.
  - Notice that the job was completed to the satisfaction of the manufacturer or manufacturer's designee.

Mr. & Mrs. Martin Contreras  
Page Four

- Contractor's invoice.
- An "as-built" sketch of the installation site done by the Howard County Health Department.

Issuance of Funds From the BRF

After review of the submitted invoice and associated documents, the Office of the Comptroller of the State of Maryland will issue a check to the property owner.

Once again the Department thanks you for participating in this important program. If you have any questions, please feel free to contact me at 410-537-3678 or 800-633-6101 ext 3678 or e-mail at [jboris@mde.state.md.us](mailto:jboris@mde.state.md.us).

Sincerely,

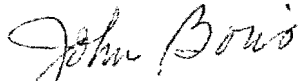

John A. Boris, Jr., R.S.  
Bay Restoration Fund Project Manager

Enclosure

cc: Jay Prager  
Howard County Health Department ✓

501

**AGREEMENT AND EASEMENT FOR INSTALLATION  
OF BEST AVAILABLE TECHNOLOGY SYSTEMS  
WITH BAY RESTORATION FUNDS.**

THIS AGREEMENT is made this 28th day of February, among Martin & Minerva Contreras  
\_\_\_\_\_, hereinafter referred to as "Owner," the Howard County Health Department hereinafter  
collectively referred to as the "County," and the Department of the Environment, hereinafter referred to as  
the "Department."

WHEREAS, Owner owns a tract of land located on 16985 Moss Meadow Way, Mt. Airy  
\_\_\_\_\_, in the 4th Election District of Howard County, Maryland, and the deed to same is  
recorded among the Land Records of Howard County, Maryland, in Ellicott City  
and in Liber 9624 Folio 415.

WHEREAS, the Bay Restoration Fund (BRF) may provide a grant for the cost attributable to  
upgrading an onsite sewage disposal system to the Best Available Technology (BAT) for the removal of  
nitrogen.

WHEREAS, the BRF may also provide a grant for the cost difference between a traditional onsite  
sewage disposal system and a system that utilizes the BAT for the removal of nitrogen.

WHEREAS, Owner understands that participation in the Bay Restoration Fund is voluntary.

NOW, THEREFORE, the parties hereto agree as follows:

- A. Owner hereby grants to the Department and the County the right to enter upon the property at  
any reasonable time for access to the system to make periodic inspections and the Owner  
agrees to provide any information and data requested and needed by the Department to  
develop accurate and thorough test results.
- B. Owner acknowledges and agrees that a manufacturer-approved installer will install the BAT  
system.

- C. Owner acknowledges and agrees the manufacturer will provide for Operation and Maintenance of the BAT for a period of 5 years as a condition of sale of the BAT. After the 5 year period the Operation and Maintenance contract can be further extended at the behest of the property owner. The Department and County encourage the property owner to continuously maintain an Operation and Maintenance contract during the lifetime of the system.
- D. Owner acknowledges and agrees that the manufacturer appointed Operation and Maintenance provider will have access to the BAT system at all times.
- E. Owner acknowledges and agrees that the manufacturer or manufacturers designee will have access to sample the effluent of the BAT system. Owner acknowledges and agrees that the proposed installation of a BAT system funded by the BRF is voluntary. Owner agrees that there shall be no liability on the part of the County or Department to Owner if this BAT system fails, and that the County and the Department do not warrant or guarantee that the BAT system will adequately or properly function.
- F. Owner acknowledges and agrees that neither the County nor the Department nor any of its agents or employees, either officially or individually, underwrites the operation of any system approved by them.
- G. The Owner will devote such care and effort to the maintenance of the BAT system so that any malfunction is not the result of poor maintenance, faulty operation, or neglect.
- H. The Department and/or County agree to grant \$ 13,525 toward the cost of installation of the BAT System, and financial responsibility is limited to this amount. Owner will present to the County at least 3 proposals from manufacturer and County certified system installers demonstrating the total cost of installation. Operating costs will be at the Owner's expense.

- I. The Owner acknowledges that the BRF grant can only be used for that portion of the OSDS attributable to (BAT) for the removal of nitrogen.
- J. Owner acknowledges in the event the total project cost is greater than \$25,000 the proposal will have to be approved by the Maryland State Board of Public Works.
- K. The Owner agrees to contact both the Water Management Administration, On-Site Systems Division of the Wastewater Permits Program and the County at least forty-eight (48) hours prior to system installation, so that the Department has the opportunity to be present at the time of installation or thereafter for inspection.
- L. The Owner must install BAT system according to the manufacturer recommended plans and specifications approved by the Department.
- M. The Owner agrees and acknowledges that if installation deviates substantially from the approved plans or changes such that performance of the system is compromised or reduced, BRF funding will not be provided.
- N. This agreement shall run with the land and binds the Owner, his heirs, successors, assigns except that the provisions of paragraph A, C, D and E shall be binding for a period of 5 years only after installation of the system and occupation of the home. Owner further agrees that he shall inform in writing any purchaser or lessee of the property that the system may require maintenance or other attention. The Owner agrees to record this agreement in the land records of Howard County.
- O. This agreement shall not be construed to limit any authority of the Department to protect the public health, safety or comfort or to issue any other orders to take any other action that is now or may hereafter be within its authority.
- P. This agreement may be voided at the discretion of the Department if the system construction is not completed within six (6) months of the effective date of this agreement.

Q. This agreement contains the entire agreement and understanding between the County and the Owner and the Department. There are no additional terms other than as contained in this agreement. This agreement may not be modified except in writing signed by each of the parties or by their authorized representatives.

R. The laws of the State of Maryland govern the provisions of all transactions pursuant to this agreement.

IN WITNESS WHEREOF, the parties have signed and sealed this agreement on the date indicated above.

DATE: 6/11/08

[Signature]  
Owner J. Martin Contreras Minerva Contreras

DATE: 2/22/08

[Signature]  
Jay Prager, Deputy Program Manager  
Wastewater Permits Program  
Maryland Department of the Environment

DATE: \_\_\_\_\_

\_\_\_\_\_  
Howard County

IMP FD SURE \$ 20.00  
RECORDING FEE 20.00  
TOTAL 40.00  
Res# H002 Kcpt # 45470  
MOR TLR Bk # 2049  
Jun 27 2008 09:11 am