

LAYOUT _____ INSP 4 _____
INSP 2 3/28/08 INSP 5 _____
INSP 3 _____ INSP 6 _____

ISSUE DATE: 3/21/08 **PERMIT-MICROFAST 0.5** P 528523

APPROVAL DATE: 4-10-08 **SEPTIC SYSTEM** A 519685
Logged Into Permit Manager
TAX ID # 04-330110

**ON-SITE SEWAGE DISPOSAL SYSTEM
HOWARD COUNTY HEALTH DEPARTMENT
BUREAU OF ENVIRONMENTAL HEALTH**

Fogles Septic Service IS PERMITTED TO INSTALL ALTER

ADDRESS: 14356 Dorsey Mill Road PHONE NUMBER: _____

CITY: Glenwood Parcel 116

ADDRESS: 14356 Dorsey Mill Road PROPERTY OWNER: Mr. & Mrs. Calvert

ADVANCED PRETREATMENT: _____
**Top Seamed watertight Tank with
a MicroFAST 0.5**

LOCATION:	Install Microfast Unit 0.5 to existing system as shown on approved plan
NOTES:	System is sized for a maximum of 4 bedrooms. Future additions to the property are not possible due to limited on-site sewage disposal area unless public water or sewer becomes available. Pretreatment must be installed prior to release of the building permit B07004186.

Note: Advanced pretreatment is required due to down gradient neighboring wells.

PLANS APPROVED: Michael Davis DATE: 11/27/08

NOTES: PERMIT VOID AFTER 1 YEARS
CONTRACTOR IS RESPONSIBLE FOR SCHEDULING A PRE-CONSTRUCTION INSPECTION FOR ALL INSTALLATIONS
WATERTIGHT SEPTIC TANKS REQUIRED
ALL PARTS OF SEPTIC SYSTEM SHALL BE 100 FEET FROM ANY WATER WELL UNLESS SPECIFICALLY AUTHORIZED
MANHOLE RISERS REQUIRED ON ALL SEPTIC TANKS AND PUMP CHAMBERS UNLESS SPECIFICALLY AUTHORIZED
CONTRACTOR RESPONSIBLE FOR COMPLIANCE WITH APPLICABLE REGULATIONS, GUIDELINES AND THE TERMS OF THIS PERMIT

**NEITHER THE HOWARD COUNTY COUNCIL NOR THE HEALTH DEPARTMENT IS
RESPONSIBLE FOR THE SUCCESSFUL OPERATION OF ANY SYSTEM
PERMITTEE RESPONSIBLE FOR OBTAINING FINAL APPROVAL ON THIS PERMIT
ALL 410-313-1771 FOR INSPECTION OF SEPTIC SYSTEM**

*Jeff Calvert
(301) 252-9344*

NOT TO SCALE
Dorsey M/Road

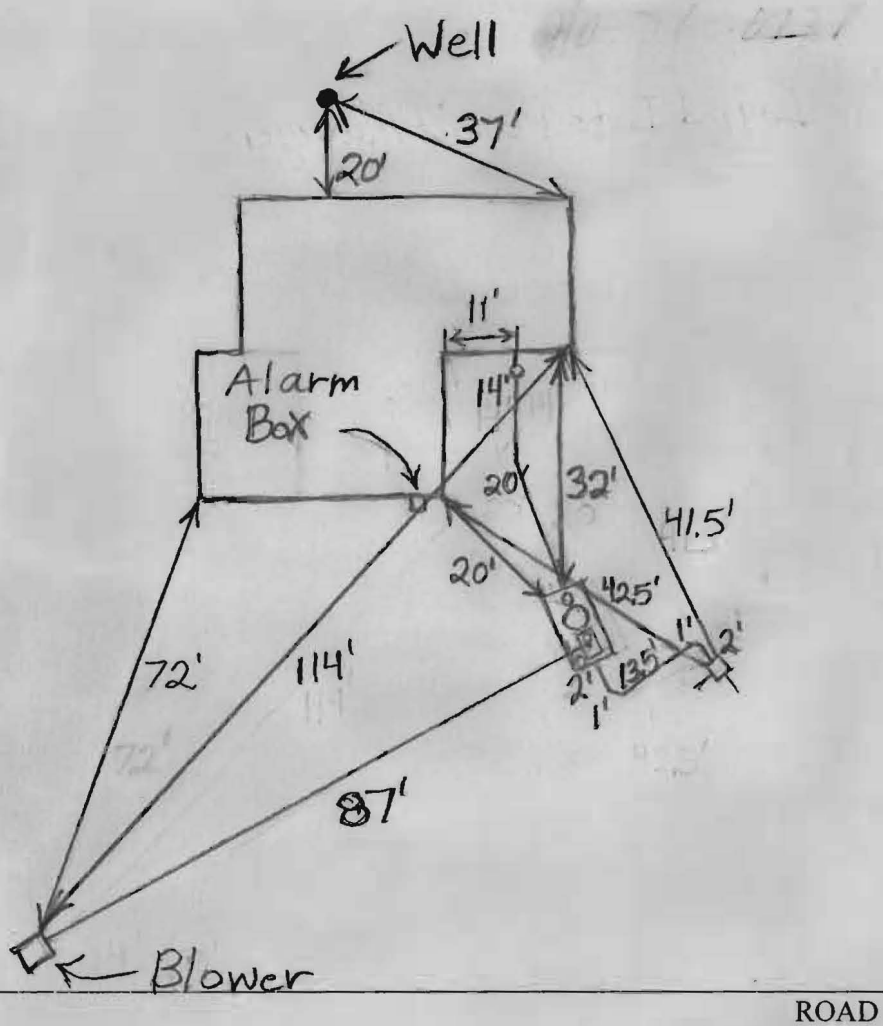

TRENCH/DRAINFIELD DATA		
WIDTH	INLET	BOTTOM
<i>Existing</i>		
NUMBER OF TRENCHES	<i>2</i>	
TOTAL LENGTH	<i>100'</i>	
ABSORPTION AREA	_____	
DISTRIBUTION BOX LEVEL	<i>Levelers</i>	
DISTRIBUTION BOX BAFFLE	<i>No</i>	
DISTRIBUTION BOX PORT	<i>No</i>	

SEPTIC TANK DATA		
SEPTIC TANK 1 LEVEL	<i>N/A</i>	
CAPACITY	_____	GAL
SEAM LOC	_____	
TANK LID DEPTH	_____	
BAFFLES	_____	
BAFFLE FILTER	_____	
MANHOLE LOC	_____	
6" PORT LOC	_____	
WATERTIGHT TEST	_____	
PUMP TANK 1 LEVEL	<i>N/A</i>	
CAPACITY	_____	GAL
SEAM LOC	_____	
TANK LID DEPTH	_____	
BAFFLES	_____	
BAFFLE FILTER	_____	
MANHOLE LOC	_____	
6" PORT LOC	_____	
WATERTIGHT TEST	_____	
MICROFAST 0.75 TANK LEVEL	<i>Yes</i>	
CAPACITY	<i>1500</i>	GAL
SEAM LOC	<i>Top</i>	
TANK LID DEPTH	<i>1.5'</i>	
BAFFLES	<i>Front, 2 Middle</i>	
BAFFLE FILTER	<i>No</i>	
MANHOLE LOC	<i>Middle</i>	
6" PORT LOC	<i>Front</i>	
WATERTIGHT TEST	<i>No</i>	

PRE-CONSTRUCTION

3/28/08

INSTALLATION

3/28/08 Need house connection. Need to confirm that alarm, blower and fast unit are operating correctly. Need inspection by Firewire and Associates. (PB)

4/10/08 House connection made.

Startup test confirmed. Alarm check good. System OK.

3/9/09 2 piece well cap installed (50)

FINAL INSPECTOR *John Way*

DATE OF APPROVAL *4-10-08*



MARYLAND DEPARTMENT OF THE ENVIRONMENT

1800 Washington Boulevard • Baltimore MD 21230

410-537-3000 • 1-800-633-6101

Martin O'Malley
Governor

Shari T. Wilson
Secretary

Anthony G. Brown
Lieutenant Governor

Robert M. Summers, Ph.D.
Deputy Secretary

3/19/2008

Jeff & Karen Calvert
9500 Whiskey Bottom Road
Laurel, MD 20723
Tax Map 21, Grid 17, Parcel 116

Dear Mr. & Mrs. Calvert,

Your bid package for the Bay Restoration Fund (BRF) Onsite Sewage Disposal System (OSDS) Program has been approved for the use of funds totaling not more than \$9,850. The accepted bid amount is for the installation of a MicroFAST .5 for your property located at 14356 Dorsey Mill Road, Glenwood, MD and shown on Tax Map 21, Parcel 116. You may choose to deviate from the selected unit, however the grant award for acceptable reimbursable expenses may not exceed \$9,850. All grants awarded through the Maryland Department of the Environment (MDE) are reimbursable. This means that all work done prior to this letter cannot be considered for reimbursement. In order to be eligible for reimbursement you must sign and record a copy in the land records of Howard County the Agreement and Easement for Installation of Best Available Technology Systems with Bay Restoration Funds. You must provide MDE with the following:

- The contractors' invoice. This invoice should include everything quoted in the bid. All expenditures greater than the bid amount will not be covered.
- A copy of the installation inspection performed by the Howard County Environmental Health program.
- A signed statement from the BAT Manufacturer that the unit was installed to their specific installation instructions.
- A signed statement that all work completed has met your satisfaction.
- A completed State Grant or Loan Payment Disbursement Request Form
- A copy of the Agreement and Easement for Installation of Best Available Technology Systems with Bay Restoration that shows that it has been recorded in the land records of Howard County.

All submitted documentation would be reviewed for compliance. Once all documentation is submitted, you will receive a payment directly from the State comptroller's office.

The Maryland Department of the Environment thanks you for participating in this important program. If you have any further questions, please feel free to contact me at 410-537-3678 or 1-800-633-6101 ext 3678 or email at jboris@mde.state.md.us.

Sincerely,

John A. Boris, Jr., R.S.
Bay Restoration Fund Project Manager

Call Land Records

cc: Jay Prager
Howard County Health Department
Jag Khuman, WQFA

Enclosures

**AGREEMENT AND EASEMENT FOR INSTALLATION
OF BEST AVAILABLE TECHNOLOGY SYSTEMS
WITH BAY RESTORATION FUNDS.**

THIS AGREEMENT is made this 18th day of March, among Jeff & Linda Calvert, hereinafter referred to as "Owner," the Howard County Health Department hereinafter collectively referred to as the "County," and the Department of the Environment, hereinafter referred to as the "Department."

WHEREAS, Owner owns a tract of land located on 14356 Dorsey Mill Road, Glenwood, MD, in the 4th Election District of Howard County, Maryland, and the deed to same is recorded among the Land Records of Howard County, Maryland, in Ellicott City and in Liber 10512 Folio 546.

WHEREAS, the Bay Restoration Fund (BRF) may provide a grant for the cost attributable to upgrading an onsite sewage disposal system to the Best Available Technology (BAT) for the removal of nitrogen.

WHEREAS, the BRF may also provide a grant for the cost difference between a traditional onsite sewage disposal system and a system that utilizes the BAT for the removal of nitrogen.

WHEREAS, Owner understands that participation in the Bay Restoration Fund is voluntary.

NOW, THEREFORE, the parties hereto agree as follows:

- A. Owner hereby grants to the Department and the County the right to enter upon the property at any reasonable time for access to the system to make periodic inspections and the Owner agrees to provide any information and data requested and needed by the Department to develop accurate and thorough test results.
- B. Owner acknowledges and agrees that a manufacturer-approved installer will install the BAT system.

- C. Owner acknowledges and agrees the manufacturer will provide for Operation and Maintenance of the BAT for a period of 5 years as a condition of sale of the BAT. After the 5 year period the Operation and Maintenance contract can be further extended at the behest of the property owner. The Department and County encourage the property owner to continuously maintain an Operation and Maintenance contract during the lifetime of the system.
- D. Owner acknowledges and agrees that the manufacturer appointed Operation and Maintenance provider will have access to the BAT system at all times.
- E. Owner acknowledges and agrees that the manufacturer or manufacturer's designee will have access to sample the effluent of the BAT system. Owner acknowledges and agrees that the proposed installation of a BAT system funded by the BRF is voluntary. Owner agrees that there shall be no liability on the part of the County or Department to Owner if this BAT system fails, and that the County and the Department do not warrant or guarantee that the BAT system will adequately or properly function.
- F. Owner acknowledges and agrees that neither the County nor the Department nor any of its agents or employees, either officially or individually, underwrites the operation of any system approved by them.
- G. The Owner will devote such care and effort to the maintenance of the BAT system so that any malfunction is not the result of poor maintenance, faulty operation, or neglect.
- H. The Department and/or County agree to grant \$ 9,850 toward the cost of installation of the BAT System, and financial responsibility is limited to this amount. Owner will present to the County at least 3 proposals from manufacturer and County certified system installers demonstrating the total cost of installation. Operating costs will be at the Owner's expense.

- I. The Owner acknowledges that the BRF grant can only be used for that portion of the OSDS attributable to (BAT) for the removal of nitrogen.
- J. Owner acknowledges in the event the total project cost is greater than \$25,000 the proposal will have to be approved by the Maryland State Board of Public Works.
- K. The Owner agrees to contact both the Water Management Administration, On-Site Systems Division of the Wastewater Permits Program and the County at least forty-eight (48) hours prior to system installation, so that the Department has the opportunity to be present at the time of installation or thereafter for inspection.
- L. The Owner must install BAT system according to the manufacturer recommended plans and specifications approved by the Department.
- M. The Owner agrees and acknowledges that if installation deviates substantially from the approved plans or changes such that performance of the system is compromised or reduced, BRF funding will not be provided.
- N. This agreement shall run with the land and binds the Owner, his heirs, successors, assigns except that the provisions of paragraph A, C, D and E shall be binding for a period of 5 years only after installation of the system and occupation of the home. Owner further agrees that he shall inform in writing any purchaser or lessee of the property that the system may require maintenance or other attention. The Owner agrees to record this agreement in the land records of Howard County.
- O. This agreement shall not be construed to limit any authority of the Department to protect the public health, safety or comfort or to issue any other orders to take any other action that is now or may hereafter be within its authority.
- P. This agreement may be voided at the discretion of the Department if the system construction is not completed within six (6) months of the effective date of this agreement.

Q. This agreement contains the entire agreement and understanding between the County and the Owner and the Department. There are no additional terms other than as contained in this agreement. This agreement may not be modified except in writing signed by each of the parties or by their authorized representatives.

R. The laws of the State of Maryland govern the provisions of all transactions pursuant to this agreement.

IN WITNESS WHEREOF, the parties have signed and sealed this agreement on the date indicated above.

DATE: _____

Owner

DATE: 2/18/08

Jay Prager, Deputy Program Manager
Wastewater Permits Program
Maryland Department of the Environment

DATE: 5/1/08

Bert Nifan
Howard County

9500 whiskey bottom @
20723



Bob

John R. Barr †
Fred L. Coover †

Richard A. Mlynek ††
Gabriel A. Riveros

† Also admitted in District of Columbia
†† Also admitted in Connecticut & Texas

January 24, 2007

Office of Administrative Hearings
11101 Gilroy Road
Hunt Valley, Maryland 21031

Attention: Kimberly Canada-Docket Specialist, MISC Unit

Re: ***In the Matter of James H. and Christina M. Selfridge
Before an Administrative Law Judge of the Office
of Administrative Hearings
Case No. MDE-LHD-054-06-47998
Our File No. 21-0906-10059***

Dear Ms. Canada:

Per our discussion earlier today, please find enclosed, a Dismissal of Appeal for filing in the above-referenced matter. Please contact my Paralegal, Jen Zepp with any questions or concerns you may have.

We will otherwise assume that this matter will be removed from the Docket on February 12th, 2007 [Telephone Prehearing Conference]. Thank you for your assistance in this matter. I remain,

Very truly yours,

COOVER & BARR, LLC-ATTORNEYS AT LAW

By:

Fred L. Coover, Esquire

FLC/jjz
Enclosure

Kimberly Canada-Docket Specialist, MISC Unit
January 24, 2007
Page 2

cc: Nancy Young, Esquire AAG
Office of the Attorney General
Department of the Environment
1800 Washington Blvd.
Baltimore, Maryland 21230

Dr. Penny E. Borenstein, M.D., M.P.H, Health Officer
Howard County Health Department
7178 Columbia Gateway Drive
Columbia, Maryland 21046

James H. Selfridge, Trustee
Christina M. Selfridge, Trustee
James H. Selfridge Builders, Inc.

IN THE MATTER OF
James H. and Christina Selfridge

* BEFORE AN ADMINISTRATIVE
* LAW JUDGE OF THE OFFICE
* OF ADMINISTRATIVE HEARINGS
* CASE NO. MDE-LHD-054-06-47998

* * * * *

DISMISSAL OF APPEAL

Appellants, James H. Selfridge, Trustee and Christina M. Selfridge, Trustee,
Property Owners; and James H. Selfridge Builders, Inc., Contractor, by and through
Fred L. Coover, Esquire, and **COOVER & BARR, LLC-ATTORNEYS AT LAW**, their attorneys,
hereby dismiss without prejudice, the appeal filed in the above-referenced matter.

Respectfully submitted,

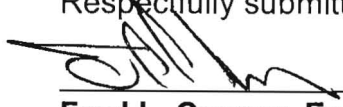

Fred L. Coover, Esquire
COOVER & BARR, LLC-ATTORNEYS AT LAW
10500 Little Patuxent Parkway
Suite 420-Parkside Building
Columbia, Maryland 21044
(410) 995-1100
Toll Free (866) 425-9555
fcoover@cooverbarr.com

Attorney for Appellants

Suite 420 - Parkside Building
10500 Little Patuxent Parkway
Columbia, Maryland 21044-3563

410-997-7600 410-995-1100
301-410-997-7606
www.cooverbarr.com



CERTIFICATE OF SERVICE

I HEREBY CERTIFY that on this 24th day of January, 2007, a copy of the foregoing Dismissal of Appeal was sent via First Class Mail-postage prepaid to:

1. Director, Water Management Administration
Department of the Environment
1800 Washington Blvd.
Baltimore, Maryland 21230

2. Nancy Young, Esquire AAG
Office of the Attorney General
Department of the Environment
1800 Washington Blvd.
Baltimore, Maryland 21230

3. Dr. Penny E. Borenstein, M.D., M.P.H, Health Officer
Howard County Health Department
7178 Columbia Gateway Drive
Columbia, Maryland 21046



Fred L. Coover, Esquire

Robert Weber

From: "Eric Dougherty" <edougherty@mde.state.md.us>
To: "Howard County Environmental Health Director" <bweber@co.ho.md.us>;
<mjdavis@co.ho.md.us>; "Barry Glotfelty" <bglotfelty@mde.state.md.us>
Cc: "Nancy Young" <nyoung@mde.state.md.us>
Sent: Friday, January 05, 2007 1:51 PM
Subject: Selfridge Appeal Status Update

The pre-hearing statement is due February 5, 2007. Ms. Nancy Young will be preparing the statement and may ask for you to review a draft. If so, please review and respond timely.

What we need from you all now is the following:

1. List of who may present testimony at the hearing;
2. Resume or CV for each identified person;
3. A short summary (2 paragraphs) of what you could/would testify about (ie: conducted site inspection; reviewed plans; county SOP for variance review is; etc).

If you have any questions, please feel free to call me. Thanks,

Eric Dougherty
Division Chief
On-Site Systems Division
MDE-WMA
410-537-3797 (o)

The information contained in this communication may be confidential, is intended only for the use of the recipient named above, and may be legally privileged.

If the reader of this message is not the intended recipient, you are hereby notified that any dissemination, distribution, or copying of this communication, or any of its contents, is strictly prohibited.

If you have received this communication in error, please re-send this communication to the sender and delete the original message and any copy of it from your computer system. Thank you.

<<<<GWIASIG 0.07>>>>