

SOILS LEGEND		
SOIL	NAME	CLASS
GbC	Gladstone Loam, 3 to 8 percent slopes	A
GnB	Glennville-Balle silt loams, 0 to 8 percent slopes	C
MgD	Manor-Bannertown sandy loams, 15 to 25 percent slopes, rocky	B
MgF	Manor-Bannertown sandy loams, 25 to 65 percent slopes, rocky	B

LEGEND	
SYMBOL	DESCRIPTION
---	EXISTING CONTOUR 2' INTERVAL
---	EXISTING CONTOUR 10' INTERVAL
---	PROPOSED CONTOUR 2' INTERVAL
---	EXISTING ELECTRIC
---	EXISTING DRIVEWAY PAVING
---	EXISTING TREE LINE
---	SOIL LINES AND TYPES
---	EXISTING ROOF LEADER
---	DENOTES EXISTING PASSED PERC
---	EXISTING SEWAGE DISPOSAL AREA

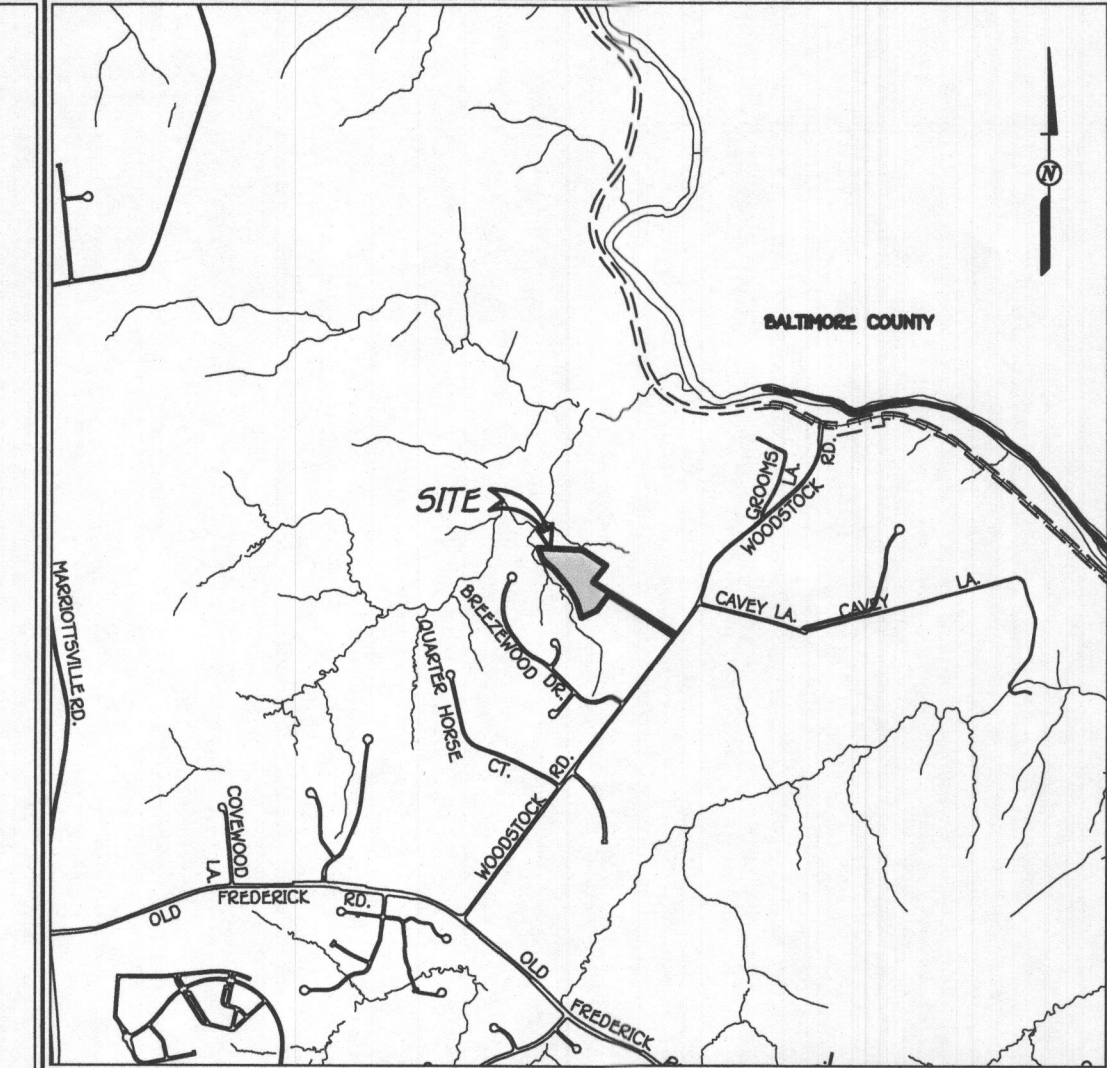

VICINITY MAP
SCALE: 1" = 2000'

- ANY CHANGE TO THE LOCATIONS OR DEPTHS TO ANY COMPONENTS MUST BE APPROVED BY THE ENGINEER AND THE HOWARD COUNTY HEALTH DEPARTMENT PRIOR TO INSTALLATION. A REVISED SITE PLAN MAY BE REQUIRED.
- ELECTRICAL WORK FOR THE INSTALLATION MUST BE PERFORMED BY A LICENSED ELECTRICIAN.
- WELL HO-15-0125 HAS BEEN FIELD LOCATED.
- ALL WELLS AND SEPTIC SYSTEMS LOCATED WITHIN 100' OF THE PROPERTY BOUNDARIES AND 200' DOWN GRADIENT OF ANY WELLS AND/OR SEPTIC SYSTEMS HAVE BEEN SHOWN.
- THE ENGINEER IS REGISTERED WITH MDE TO PROVIDE ON-SITE WASTEWATER SERVICES IN MARYLAND.
- CONTOURS ARE BASED ON A TOPOGRAPHIC FIELD RUN SURVEY PERFORMED BY FISHER, COLLINS AND CARTER ON OR ABOUT AUGUST, 2023.
- EXISTING TRENCHES BASED ON HOWARD COUNTY COUNTY AS-BUILTS.
- CONTRACTOR TO TEST PIT EXISTING SEWER HOUSE CONNECTIONS TO DETERMINE INVERTS BEFORE INSTALLATION.
- SEPTIC SYSTEM SHALL BE UPGRADED PRIOR TO BUILDING PERMIT APPROVAL DUE TO INCREASE IN SEPTIC FLOW BY PROPOSED ADDITIONAL BEDROOMS.
- CONTRACTOR TO PERFORM CONSTRUCTION PER CURRENT O.S.H.A. STANDARDS.
- CONTRACTOR TO PERFORM MINIMAL GRADING WITH SAME DAY STABILIZATION TO DETER NEGATIVE SWALE IMPACT ON EXISTING SEWAGE DISPOSAL AREA.
- INFILTRATOR TANK SPECIFICATIONS SHOULD RESEMBLE AS BEST AS POSSIBLE A STANDARD CONCRETE TANK DESIGN AND IT WILL BE THE RESPONSIBILITY OF THE SEPTIC CONTRACTOR TO ENSURE IT HAS ALL REQUIRED COMPONENTS FOR THE BEST FUNCTIONALITY AND THAT IT IS STABILIZED IN THE GROUND UPON INSPECTION.

THE PURPOSE OF THIS SEPTIC INSTALL PLAN IS TO UPGRADE THE SEPTIC SYSTEM FOR THE PROPOSED ADDITION THAT INCLUDES A TANK UPGRADE FROM ONE 1,500 GALLON TANK TO TWO 1,500 GALLON PLASTIC TANKS WITH A PUMP IN THE SECOND TANK, AN ADD-ON TRENCH, AND FUTURE REPLACEMENT SYSTEMS FOR A 6-BEDROOM DESIGN.

ADD-ON TO EXISTING SYSTEM
SEWAGE DISPOSAL SYSTEM DATA - INITIAL SYSTEM
6 BEDROOMS
LOADING RATE = 6 BEDROOMS X 150 GPD/BEDROOM GPD = 900 GPD
APPLICATION RATE = 1.2
EFFECTIVE SIDEWALL BEGINS AT 3.5 FEET
TRENCH DEPTH = 7 FEET
TRENCH WIDTH (W) = 3 FEET
EFFECTIVE DEPTH (D) = 3.5 FEET
SF OF DRAINFIELD = 900 GPD / 1.2 = 750 SF
COEFFICIENT OF REDUCTION OF TRENCH LENGTH = $(W+2)/(W+1+2D) = (3+2)/(3+1+(2*3.5)) = 0.455$
TRENCH LENGTH = $750 SF \times 0.455 / 3 = 113.75$ FEET
2 TRENCHES AT 76'
TRENCH SPACING = $2D+W = (2*3) + 3 = 9'$ USE 10'
* THERE IS ONE EXISTING 76' TRENCH, ANOTHER 76' TRENCH WILL BE ADDED TO BALANCE THE SYSTEM

1ST REPLACEMENT SYSTEM
SEWAGE DISPOSAL SYSTEM DATA - INITIAL SYSTEM
6 BEDROOMS
LOADING RATE = 6 BEDROOMS X 150 GPD/BEDROOM GPD = 900 GPD
APPLICATION RATE = 1.2
EFFECTIVE SIDEWALL BEGINS AT 3.5 FEET
TRENCH DEPTH = 7 FEET
TRENCH WIDTH (W) = 3 FEET
EFFECTIVE DEPTH (D) = 3.5 FEET
SF OF DRAINFIELD = 900 GPD / 1.2 = 750 SF
COEFFICIENT OF REDUCTION OF TRENCH LENGTH = $(W+2)/(W+1+2D) = (3+2)/(3+1+(2*3.5)) = 0.455$
TRENCH LENGTH = $750 SF \times 0.455 / 3 = 113.75$ FEET
3 TRENCHES AT 58'
TRENCH SPACING = $2D+W = (2*3) + 3 = 9'$ USE 10'

2ND REPLACEMENT SYSTEM
SEWAGE DISPOSAL SYSTEM DATA - INITIAL SYSTEM
6 BEDROOMS
LOADING RATE = 6 BEDROOMS X 150 GPD/BEDROOM GPD = 900 GPD
APPLICATION RATE = 1.2
EFFECTIVE SIDEWALL BEGINS AT 3 FEET
TRENCH DEPTH = 8 FEET
TRENCH WIDTH (W) = 3 FEET
EFFECTIVE DEPTH (D) = 3 FEET
SF OF DRAINFIELD = 900 GPD / 1.2 = 750 SF
COEFFICIENT OF REDUCTION OF TRENCH LENGTH = $(W+2)/(W+1+2D) = (3+2)/(3+1+(2*3)) = 0.357$
TRENCH LENGTH = $750 SF \times 0.357 / 3 = 89.3$ FEET
2 TRENCHES AT 45'
TRENCH SPACING = $2D+W = (2*3) + 3 = 9'$ USE 13'

Approved Septic System Plan
Howard County Health Department
4/8/24
Date

DAILY STABILIZATION NOTE:
CONTRACTOR SHALL ONLY DISTURB THAT AREA WHICH CAN BE COMPLETED AND STABILIZED BY THE END OF EACH WORKING DAY. STABILIZATION SHE BE AS FOLLOWS.
1. FOR AREAS TO BE PAVED, THAT APPLICATION OF STONE BASE.
2. FOR AREAS TO BE VEGETATIVELY STABILIZED:
A. PERMANENT SEED AND SOIL STABILIZATION MATTING OR SOD FOR ALL STEEP SLOPES, CHANNELS OR SWALES.
B. PERMANENT SEED AND MULCH FOR ALL OTHER AREAS.
ANY AREAS WHICH CAN NOT BE STABILIZED BY THE END OF EACH WORKING DAY MUST HAVE SILT FENCE INSTALLED ON THE DOWN SLOPE SIDE.

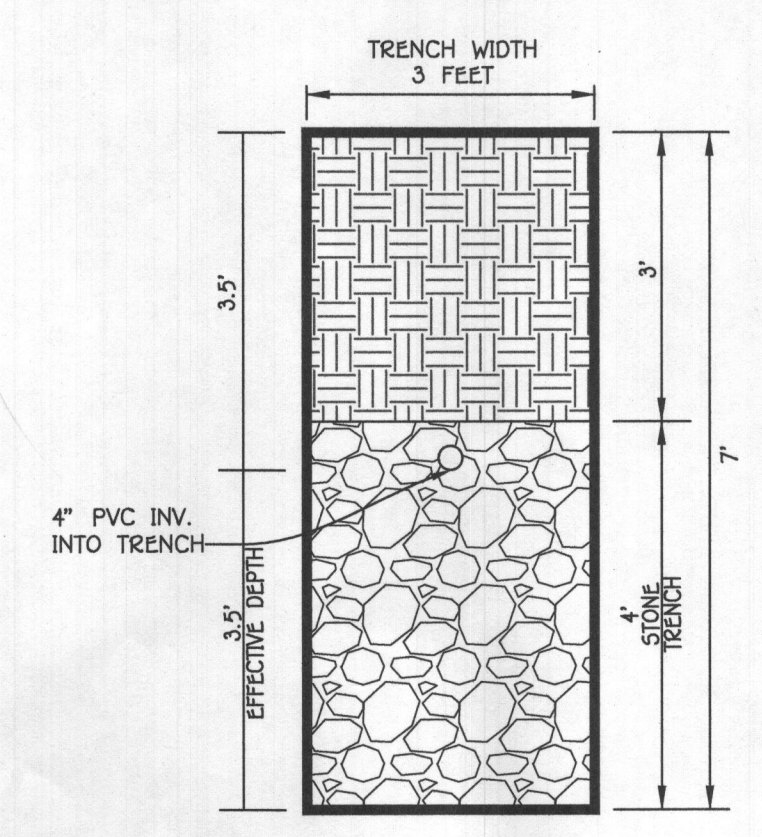
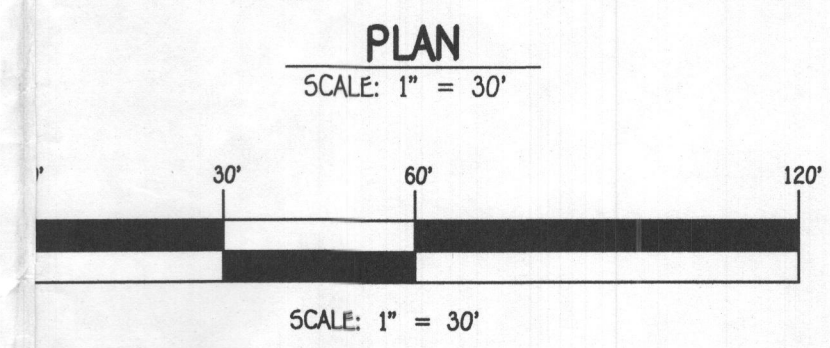

ADD-ON TRENCH DETAIL
SCALE 1" = 2'

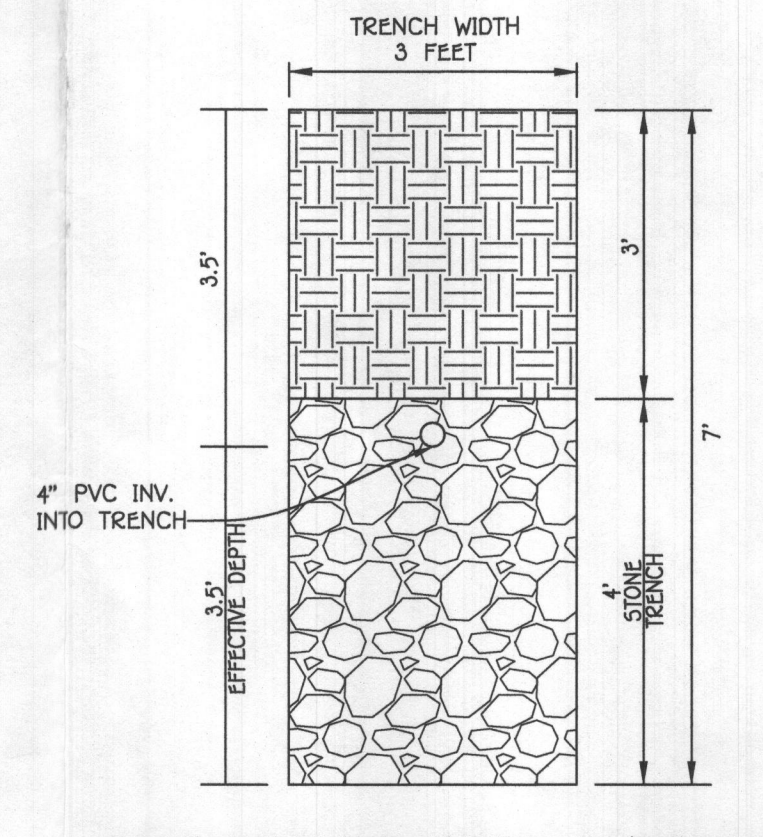

FIRST REPLACEMENT TRENCH DETAIL
SCALE 1" = 2'

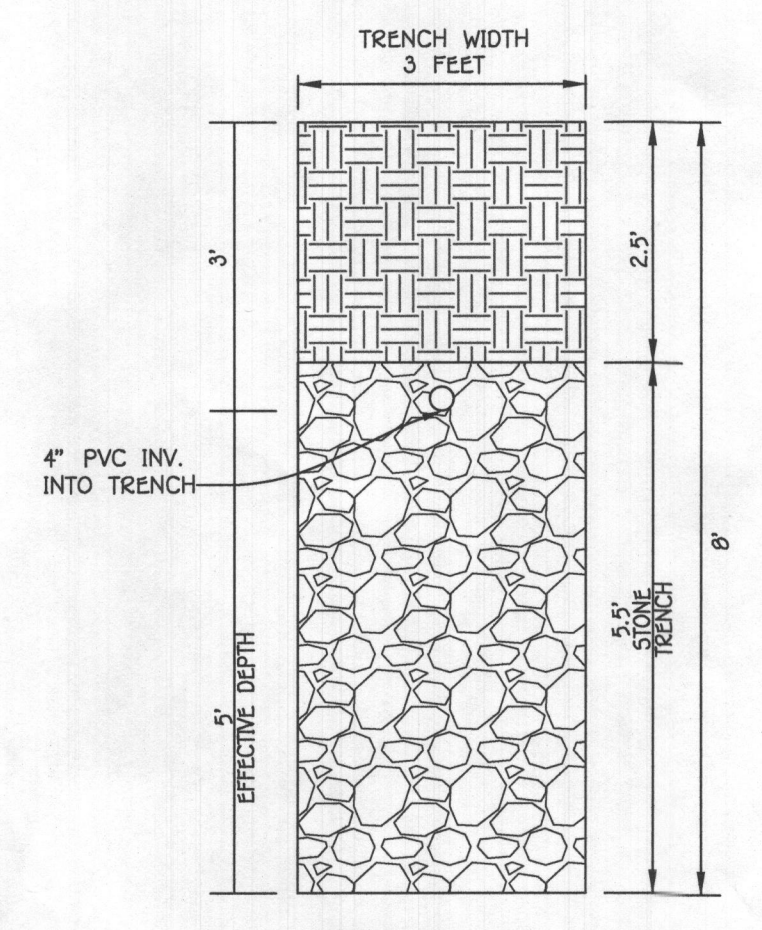

SECOND REPLACEMENT TRENCH DETAIL
SCALE 1" = 2'



PROFESSIONAL CERTIFICATION
I HEREBY CERTIFY THAT THESE DOCUMENTS WERE PREPARED OR APPROVED BY ME AND THAT I AM A DAILY LICENSED PROFESSIONAL ENGINEER UNDER THE LAWS OF THE STATE OF MARYLAND, LICENSE NO. 4609 EXPIRATION DATE: 05/14/2025.

John Brown
Signature Of Professional Engineer
DATE: 3-13-24

FISHER, COLLINS & CARTER, INC.
CIVIL, ENGINEERING, CONSULTANTS & LAND SURVEYORS
CENTENNIAL SQUARE OFFICE PARK - 10272 BALTIMORE NATIONAL PIKE
ELICOTT CITY, MARYLAND 21092
(410) 461-2895

SEPTIC INSTALL PLAN
1680 WOODSTOCK ROAD
ZONING: RC-DEO
TAX MAP No. 10 GRID No. 18 PARCEL No. 50
THIRD ELECTION DISTRICT HOWARD COUNTY, MARYLAND
SCALE: AS SHOWN DATE: MARCH, 2023
SHEET 1 OF 2

SOILS LEGEND		
SOIL	NAME	CLASS
GbC	Gladstone Loam, 3 to 8 percent slopes	A
GnB	Glenville-Balle silt loams, 0 to 8 percent slopes	C
MgD	Manor-Bannertown sandy loams, 15 to 25 percent slopes, rocky	B
MgF	Manor-Bannertown sandy loams, 25 to 65 percent slopes, rocky	B

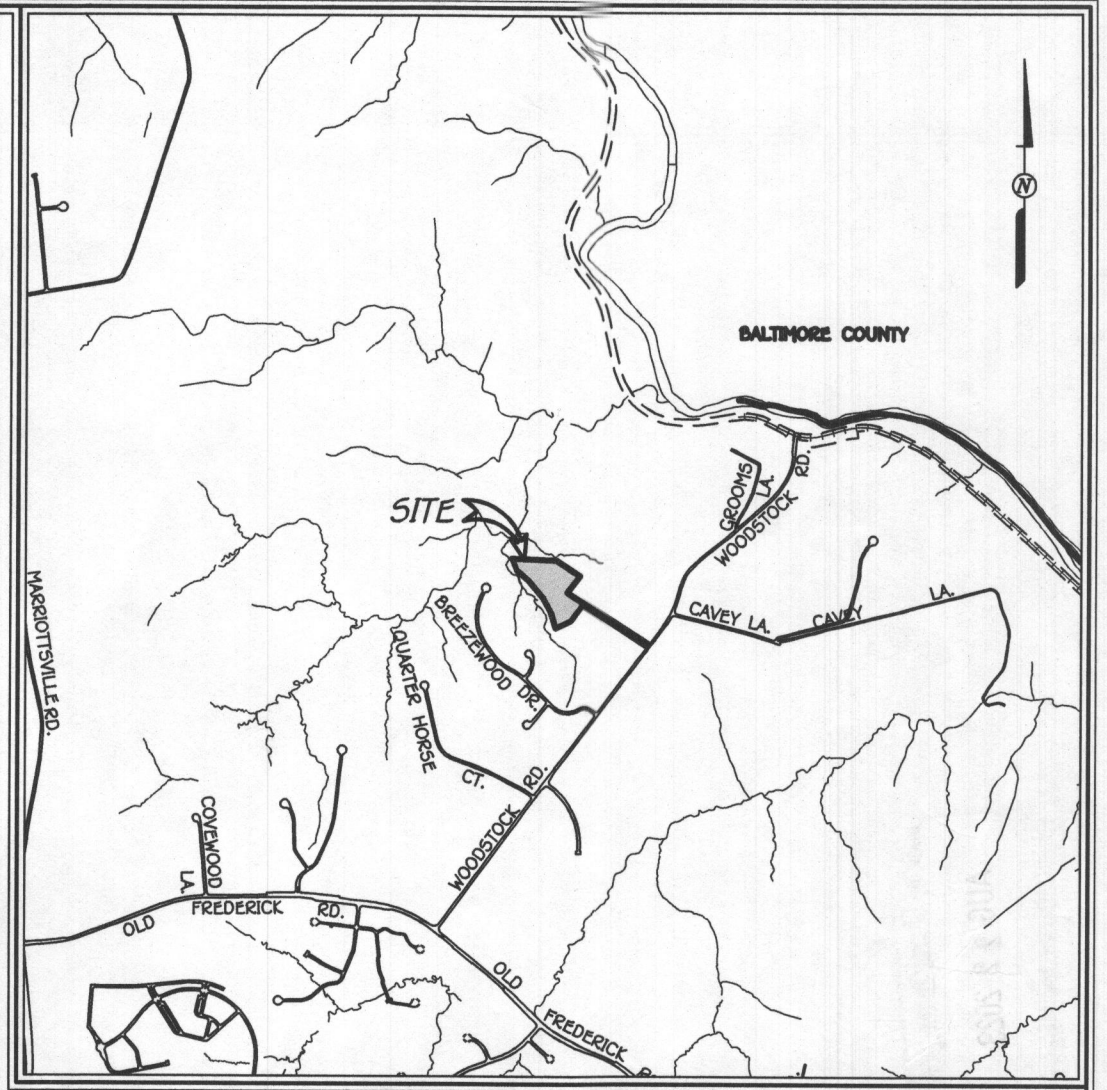

VICINITY MAP
SCALE: 1" = 2000'

LEGEND	
SYMBOL	DESCRIPTION
---	EXISTING CONTOUR 2' INTERVAL
---	EXISTING CONTOUR 10' INTERVAL
---	EXISTING ELECTRIC
---	EXISTING DRIVEWAY PAVING
---	EXISTING TREE LINE
---	SOIL LINES AND TYPES
---	EXISTING ROOF LEADER
○	DENOTES EXISTING PASSED PERC
---	EXISTING SEWAGE DISPOSAL AREA

- ANY CHANGE TO THE LOCATIONS OR DEPTHS TO ANY COMPONENTS MUST BE APPROVED BY THE ENGINEER AND THE HOWARD COUNTY HEALTH DEPARTMENT PRIOR TO INSTALLATION. A REVISED SITE PLAN MAY BE REQUIRED.
- ELECTRICAL WORK FOR THE INSTALLATION MUST BE PERFORMED BY A LICENSED ELECTRICIAN.
- WELL HO-15-0125 HAS BEEN FIELD LOCATED.
- ALL WELLS AND SEPTIC SYSTEMS LOCATED WITHIN 100' OF THE PROPERTY BOUNDARIES AND 200' DOWN GRADIENT OF ANY WELLS AND/OR SEPTIC SYSTEMS HAVE BEEN SHOWN.
- THE ENGINEER IS REGISTERED WITH MDE TO PROVIDE ON-SITE WASTEWATER SERVICES IN MARYLAND.
- CONTOURS ARE BASED ON A TOPOGRAPHIC FIELD RUN SURVEY PERFORMED BY FISHER, COLLINS AND CARTER ON OR ABOUT AUGUST, 2023.
- EXISTING TRENCHES BASED ON HOWARD COUNTY CODE AS-BUILTS.
- CONTRACTOR TO TEST PIT EXISTING SEWER HOUSE CONNECTIONS TO DETERMINE INVERTS BEFORE INSTALLATION.

INITIAL SYSTEM

SEWAGE DISPOSAL SYSTEM DATA - INITIAL SYSTEM
 2 BEDROOMS
 LOADING RATE = 5 BEDROOMS X 150 GPD/BEDROOM = 750 GPD
 APPLICATION RATE = 1.2
 SF OF DRAINFIELD = 750 GPD / 1.2 = 625 SF
 EFFECTIVE SIDEWALL BEGINS AT 3.5 FEET
 TRENCH DEPTH = 7 FEET
 TRENCH WIDTH (W) = 3 FEET
 EFFECTIVE DEPTH (D) = 3.5 FEET
 $SF \text{ OF DRAINFIELD} = 750 \text{ GPD} / 1.2 = 625 \text{ SF}$
 COEFFICIENT OF REDUCTION OF TRENCH LENGTH = $(W+2)/(W+1+2D) = (3+2)/(3+1+(2 \times 3.5)) = 0.455$
 TRENCH LENGTH = $625 \text{ SF} \times 0.455 / 3 = 95 \text{ FEET}$
 2 TRENCHES AT 48'
 TRENCH SPACING = $2D+W = ((2 \times 3) + 3) = 9'$ USE 10'

1ST REPLACEMENT SYSTEM

SEWAGE DISPOSAL SYSTEM DATA - INITIAL SYSTEM
 2 BEDROOMS
 LOADING RATE = 5 BEDROOMS X 150 GPD/BEDROOM = 750 GPD
 APPLICATION RATE = 1.2
 EFFECTIVE SIDEWALL BEGINS AT 3 FEET
 TRENCH DEPTH = 8 FEET
 TRENCH WIDTH (W) = 3 FEET
 EFFECTIVE DEPTH (D) = 5 FEET
 $SF \text{ OF DRAINFIELD} = 750 \text{ GPD} / 1.2 = 625 \text{ SF}$
 COEFFICIENT OF REDUCTION OF TRENCH LENGTH = $(W+2)/(W+1+2D) = (3+2)/(3+1+(2 \times 5)) = 0.357$
 TRENCH LENGTH = $625 \text{ SF} \times 0.357 / 3 = 75 \text{ FEET}$
 2 TRENCHES AT 38'
 TRENCH SPACING = $2D+W = ((2 \times 5) + 3) = 13'$ USE 13'

2ND REPLACEMENT SYSTEM

SEWAGE DISPOSAL SYSTEM DATA - INITIAL SYSTEM
 2 BEDROOMS
 LOADING RATE = 5 BEDROOMS X 150 GPD/BEDROOM = 750 GPD
 APPLICATION RATE = 0.8
 EFFECTIVE SIDEWALL BEGINS AT 3 FEET
 TRENCH DEPTH = 5.5 FEET
 TRENCH WIDTH (W) = 3 FEET
 EFFECTIVE DEPTH (D) = 2.5 FEET
 $SF \text{ OF DRAINFIELD} = 750 \text{ GPD} / 0.8 = 937 \text{ SF}$
 COEFFICIENT OF REDUCTION OF TRENCH LENGTH = $(W+2)/(W+1+2D) = (3+2)/(3+1+(2 \times 2.5)) = 0.556$
 TRENCH LENGTH = $937 \text{ SF} \times 0.556 / 3 = 174 \text{ FEET}$
 2 TRENCHES AT 87'
 TRENCH SPACING = $2D+W = ((2 \times 2.5) + 3) = 8'$ USE 10'

DAILY STABILIZATION NOTE:
 CONTRACTOR SHALL ONLY DISTURB THAT AREA WHICH CAN BE COMPLETED AND STABILIZED BY THE END OF EACH WORKING DAY. STABILIZATION SHALL BE AS FOLLOWS.
 1. FOR AREAS TO BE PAVED, THAT APPLICATION OF STONE BASE.
 2. FOR AREAS TO BE VEGETATIVELY STABILIZED.
 A. PERMANENT SEED AND SOIL STABILIZATION MATTING OR SOD FOR ALL STEEP SLOPES, CHANNELS OR SWALES.
 B. PERMANENT SEED AND MULCH FOR ALL OTHER AREAS.
 ANY AREAS WHICH CAN NOT BE STABILIZED BY THE END OF EACH WORKING DAY MUST HAVE SILT FENCE INSTALLED ON THE DOWN SLOPE SIDE.

Revise.
 JJC 9/25/23

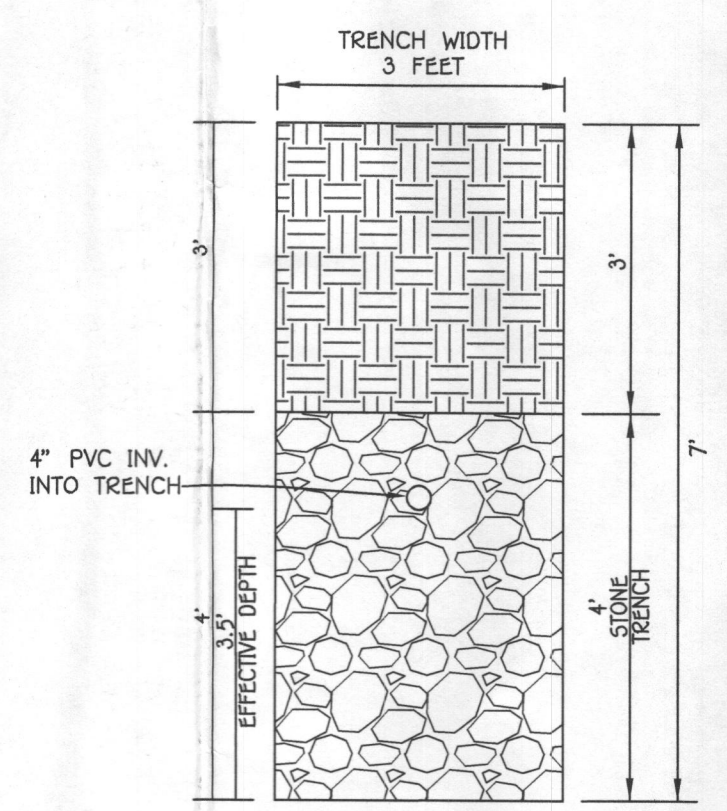
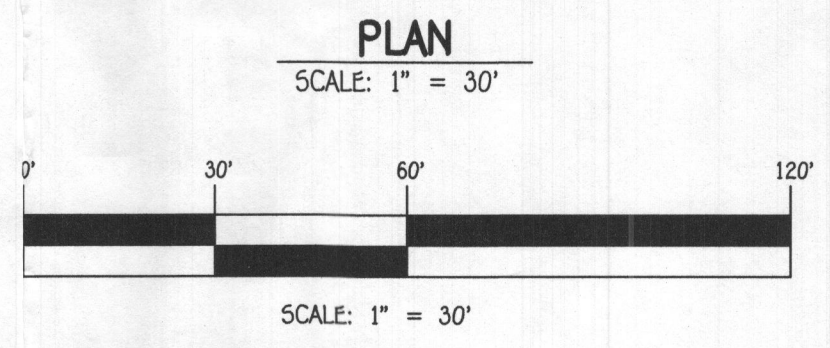

INITIAL TRENCH DETAIL
SCALE: 1" = 2'

PROFESSIONAL CERTIFICATION

I HEREBY CERTIFY THAT THESE DOCUMENTS WERE PREPARED OR APPROVED BY ME AND THAT I AM A DULY LICENSED PROFESSIONAL ENGINEER UNDER THE LAWS OF THE STATE OF MARYLAND, LICENSE NO. 46091, EXPIRATION DATE: 05/14/2025.

John Brown
 Signature of Professional Engineer

8-21-23
 DATE



FISHER, COLLINS & CARTER, INC.
 CIVIL ENGINEERING CONSULTANTS & LAND SURVEYORS
 CENTENNIAL SQUARE OFFICE PARK - 10272 BALTIMORE NATIONAL PIKE
 ELICOTT CITY, MARYLAND 21042
 (410) 461-2895

**SEPTIC INSTALL PLAN
 1680 WOODSTOCK ROAD**

ZONING: RC-DEO
 TAX MAP No. 10 GRID No. 18 PARCEL No. 50
 THIRD ELECTION DISTRICT HOWARD COUNTY, MARYLAND
 SCALE: AS SHOWN DATE: AUGUST, 2023
 SHEET 1 OF 1

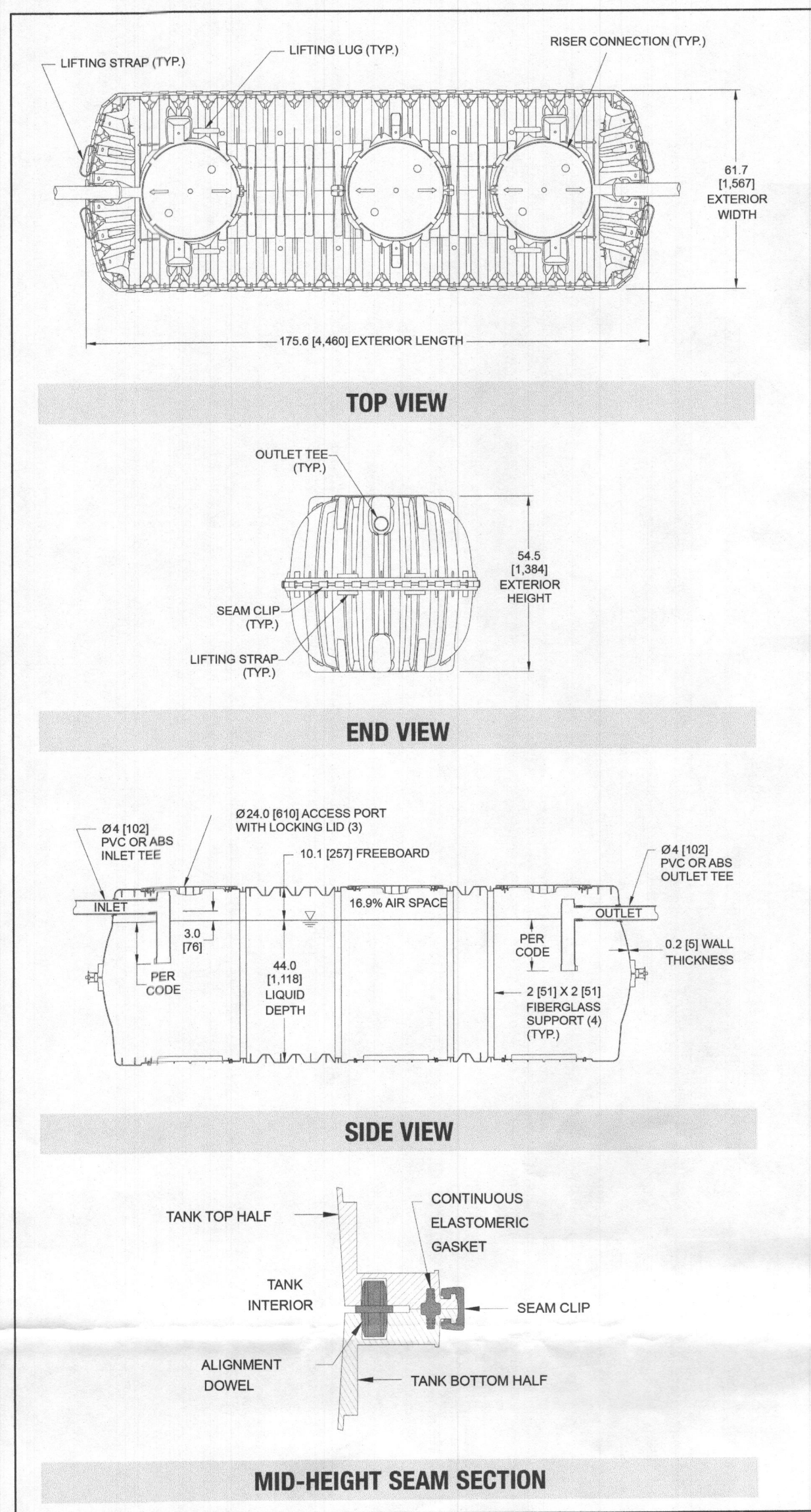

SEPTIC/PUMP TANK DETAIL INFILTRATOR IM-1530
NOT TO SCALE

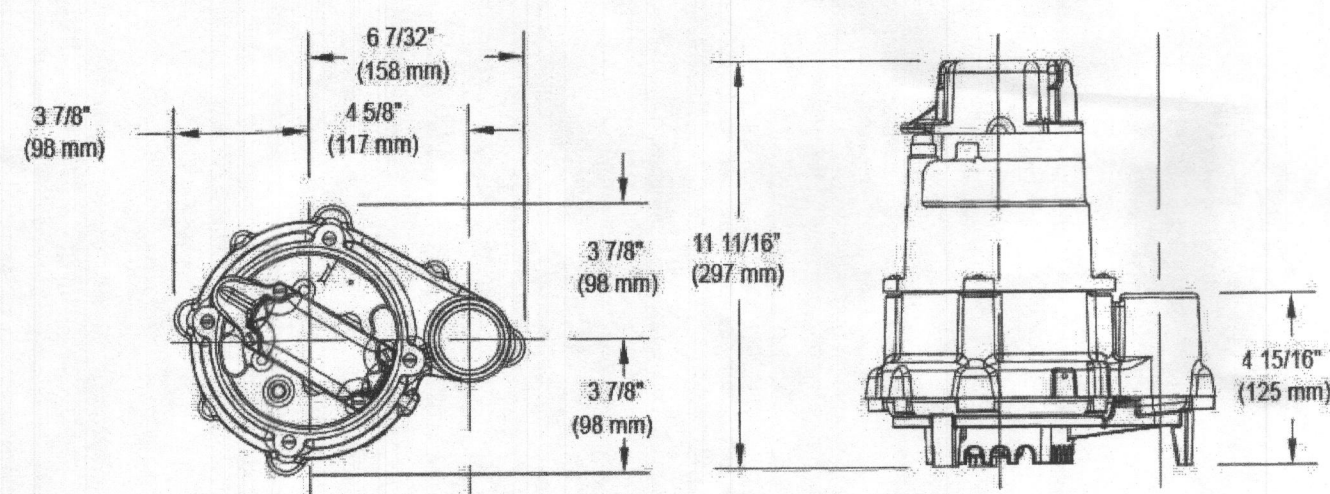

ZOELLER 151 PUMP DETAIL
NOT TO SCALE

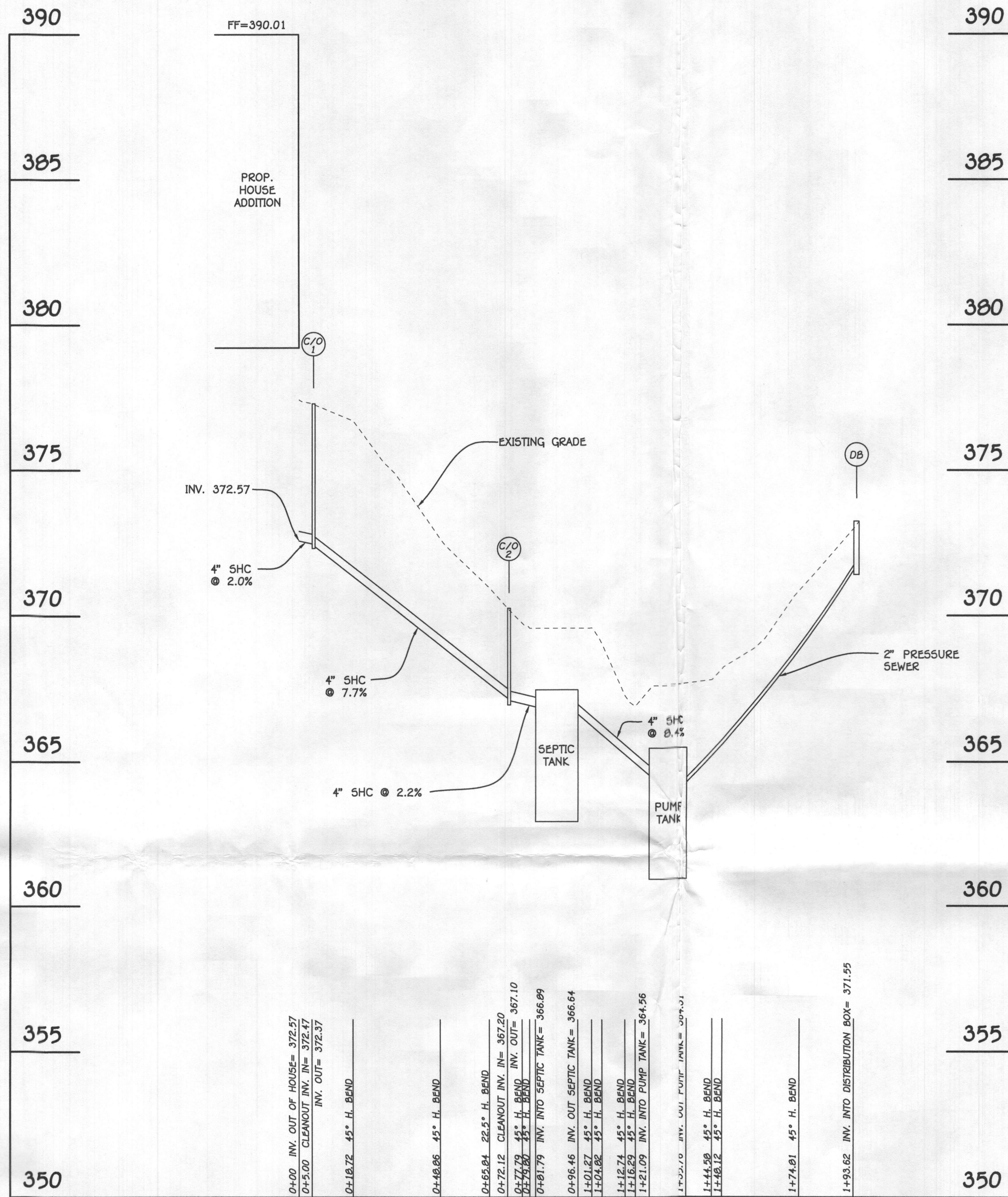

PROFILE SEPTIC
SCALE HORZ. 1" = 30'
VERT. 1" = 3'

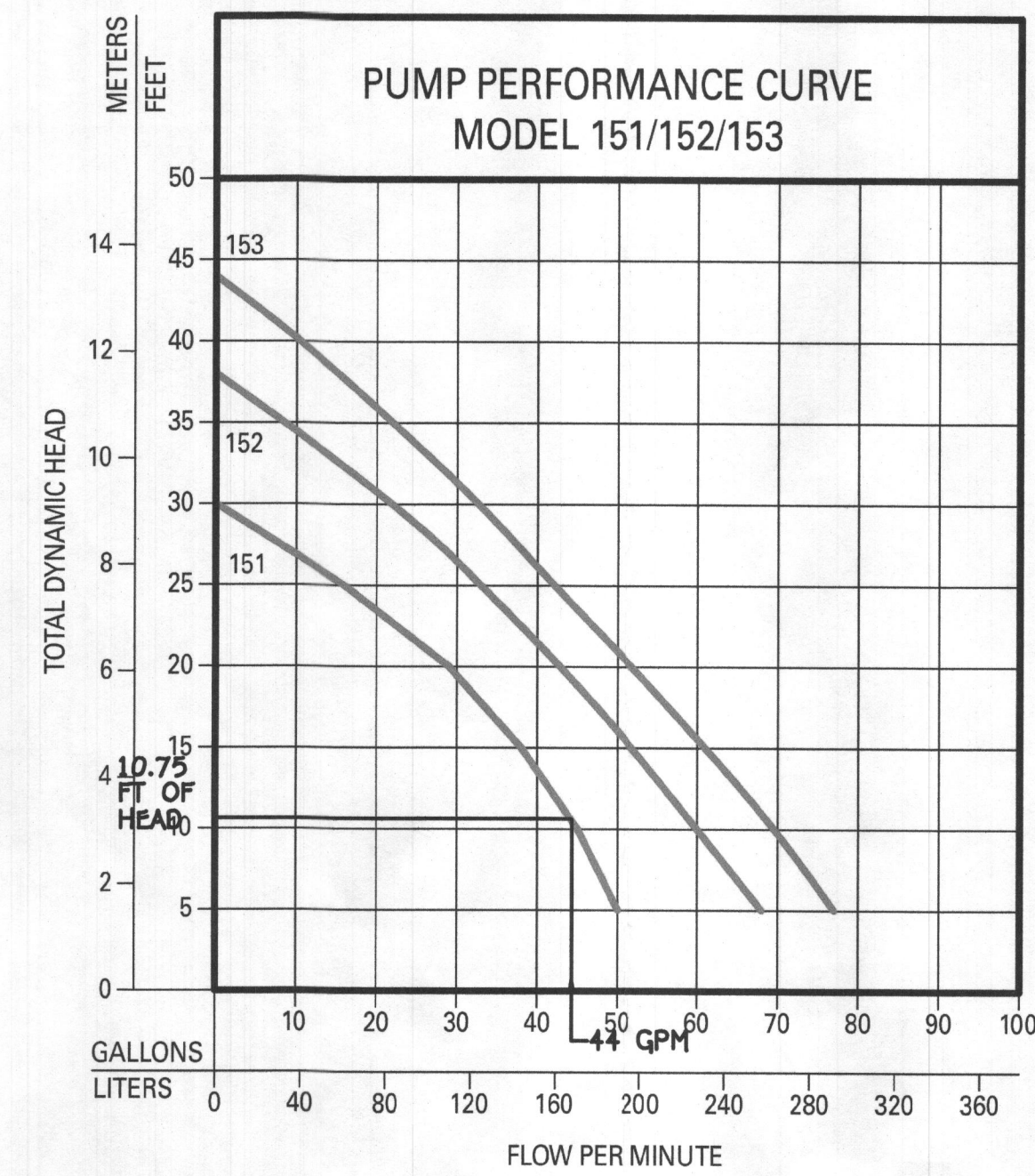

2" SCH. 40 PVC = 62 LF
1 UNION @ 2 EQUIVALENT FEET = 2 LF
3 1/8" HB @ 4 EQUIVALENT FEET = 12 LF
TOTAL LINEAR FEET OF 2" SCH. 40 PVC = 76 LF

DYNAMIC HEAD
76 LF X 2.05 FT PER 100 LF OF 2" PIPE = 1.56 FT OF FRICTION HEAD
VERTICAL FROM PUMP OFF TO HIGH POINT IN PUMP CHAMBER = 1.95 FT OF HEAD
HIGH POINT IN PUMP CHAMBER TO HIGHEST ELEV. OF SYSTEM = 7.24 FT (PUMP OUT IS THE HIGHEST POINT)
TOTAL DYNAMIC HEAD = 10.75 FT

1/6 DESIGN FLOW (900/6=150) PLUS VOLUME OF 2" PIPE (10 GALLONS)
USE 160 GALLON DOSE (150 GALLON MINIMUM)
RUN TIME = 3.64 MIN (44 GPM X 3.64 = 160 GALLON DOSE)

PUMP NEEDS TO HANDLE 44 GPM AT 10.75 FT OF HEAD
USE 0.3 HP (ZOELLER MODEL 151 PUMP)

INV. OUT OF HOUSE = 372.57
EX. GROUND AT CLEANOUT # 1 = 377.27
INV. INTO CLEANOUT = 372.47
INV. OUT OF CLEANOUT # 2 = 370.20
EX. GROUND AT CLEANOUT # 2 = 370.20
INV. INTO CLEANOUT = 366.20
INV. OUT OF CLEANOUT = 367.10
EX. GROUND AT SEPTIC TANK = 369.00
TOP OF SEPTIC TANK = 367.40
INV. INTO SEPTIC TANK = 366.89
INV. OUT OF SEPTIC TANK = 366.64
EX. GROUND AT PUMP TANK = 366.90
TOP OF PUMP TANK = 365.15
INV. INTO PUMP TANK = 364.56
INV. OUT OF PUMP TANK = 364.31
EX. GROUND AT DISTRIBUTION BOX = 372.90
INV. INTO DISTRIBUTION BOX = 371.55
INV. OUT OF DISTRIBUTION BOX = 371.45

NOTE: SEPTIC SYSTEM ALARM
WILL BE ON A CIRCUIT
SEPARATE FROM ANY
OTHER SEPTIC SYSTEM
COMPONENTS OR ALARMS.

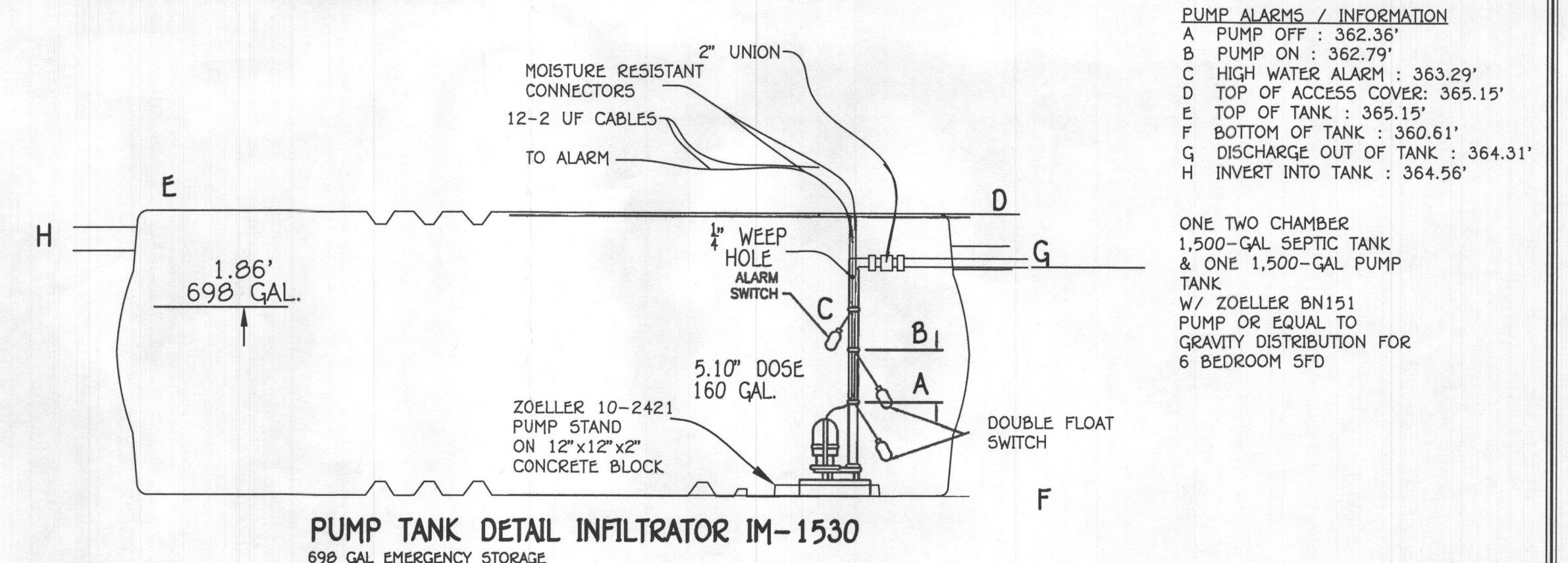

PUMP TANK DETAIL INFILTRATOR IM-1530
690 GAL EMERGENCY STORAGE

NOTE: THIS DETAIL IS TO BE USED FOR FLOAT CONFIGURATION
ONLY - SEE DETAIL ABOVE FOR TANK DIMENSIONS AND
ACTUAL LOCATION OF ACCESS COVER.

PUMP ALARMS / INFORMATION
A PUMP OFF : 362.36'
B PUMP ON : 362.79'
C HIGH WATER ALARM : 363.29'
D TOP OF ACCESS COVER: 365.15'
E TOP OF TANK : 365.15'
F BOTTOM OF TANK : 360.61'
G DISCHARGE OUT OF TANK : 364.31'
H INVERT INTO TANK : 364.56'

ONE TWO CHAMBER
1,500-GAL SEPTIC TANK
& ONE 1,500-GAL PUMP
TANK
W/ ZOELLER BN151
PUMP OR EQUAL TO
GRAVITY DISTRIBUTION FOR
6 BEDROOM SFD



PROFESSIONAL CERTIFICATION
I HEREBY CERTIFY THAT THESE DOCUMENTS WERE PREPARED OR APPROVED BY ME
AND THAT I AM A DULY LICENSED PROFESSIONAL ENGINEER UNDER THE LAWS OF
THE STATE OF MARYLAND, LICENSE NO. 46091 EXPIRATION DATE: 05/14/2025.

John Brown
Signature Of Professional Engineer

3-13-24
DATE

