

Record Detail * (This section is required.)

Permit Type	Permit Number	Opened Date
Building/Residential/Misc/Tanks	B25005269	11/24/2025
Description of Work		
SFD// INSTALL (1) 1000GAL UNDERGROUND PROPANE TANK		

12/1
not installed

[check spelling](#)

12/1/25 - si - setbacks ok
not installed yet. (R)

Approved 12/2/25
AAA

Address * (This section is required.)

Search Reset Clear Get Parcel & Owner

Street #	Street Name	Street Type
1735	BRICKELL	WAY
Unit Type	Unit #	X Coordinate
--Select--		
City	State	Zip Code
MARRIOTTSVILLE	MD	21104

Parcel * (This section is required.)

Search	Reset	Clear	Get Address & Owner			
GIS ID *	Parcel	Parcel Area	Land Value	Improved Value	Exemption Value	Plan Area
11062893	274	0	0	0	0	RURAL
Legal Description						

[check spelling](#)

Block	Lot	Census Tract	Council Dist	Inspection Dist	Supervisor Dist	Map #	DAP Zone
1	6	603000	5				
Plan Area	State Tax Id	Subdivision Name					
		Brickell Property					
Section	Area	Tax Map					
		10					
Grid	Zoning District	ADC Map					
10-1	RR-DEO	4694-A6					
SDP No.	Final Plan No.	WP File No.					
	ECP-19-021						
Record Plat No.	WS Contract No.	FDP No.	Primary				
26850-2685			Yes				
Owner Occupied	Year Built	Historic District					
<input type="radio"/> Yes <input type="radio"/> No		<input type="radio"/> Yes <input checked="" type="radio"/> No					
Historic District Registry No.	Stat Area	Flood Plain					
	3-01	<input type="radio"/> Yes <input checked="" type="radio"/> No					
Building No							

Owner * (This section is required.)

Search Reset Clear

Name *

NVR IN

Address Line 1

7080 SAMUEL MORSE DR #100

Address Line 2

Address Line 3

Mail City
 COLUMBIA
Mail State
 MD
Mail Zip Code
 21046
Phone
 301-432-6611
Primary
 Yes
E-mail

Cell Number **Fax Number**

Professionals (This section is not required.)

License # * 20100096881
License Type * Propane Gs
Primary Yes
Business Name THOMPSONGAS, LLC
First Name THOMAS
Middle Name BRADLEY
Last Name ROHRER
Address Line 1 6708 OLD NATIONAL PIKE
Address Line 2
City BOONSBORO
State MD
ZIP Code 21713
Phone 1 301-432-6611
Phone 2
Fax
E-mail BROHRER@THOMPSONGAS.COM

Applicant (This section is not required.)

Search
 As Owner
 As Lic. Prof
 As Contact

Type * Applicant
Relationship Applicant
Primary Yes
First Name MICHELLE
MI
Last Name CLANCY
Full Name MICHELLE CLANCY
Organization Name APPLIED & APPROVED PERMITS LLC
Street Address P.O. BOX 310
Address Line 2
City PERRY HALL
State MD
Zip Code 21128
Phone 443-340-1229
Cell
Fax
E-mail * MICHELLE@APPLIEDANDAPPROVED.COM

Addtl Info

Est Construction Cost * 750
Housing Units * 0
Number of Buildings * 0
Public Owned No
Construction Type 329 - Structures Other Than Buildings (Retaining Walls/Tents)

TANK INFORMATION

RESIDENTIAL TANK INFORMATION

Capital Project-No Fee * Yes No
Capital Project Number _____ (Text)
Fee Exempt * Yes No
Roadside Tree Project Permit * Yes No
Roadside Tree Permit # _____ (Text)
Existing Use * SFD
Number of Tanks Installed * 1
Number of Tanks Removed * 0
 (Number) (Number)



UNDERGROUND PROPANE STORAGE TANKS 120 - 1000 Gallons

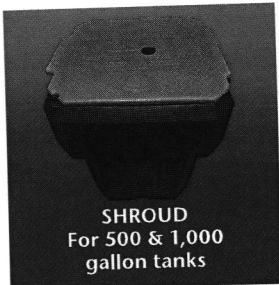

SHROUD
For 500 & 1,000
gallon tanks

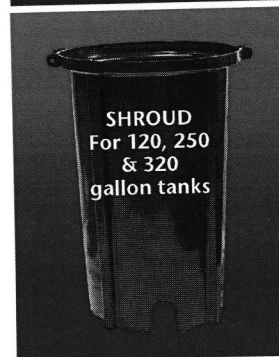

SHROUD
For 120, 250
& 320
gallon tanks

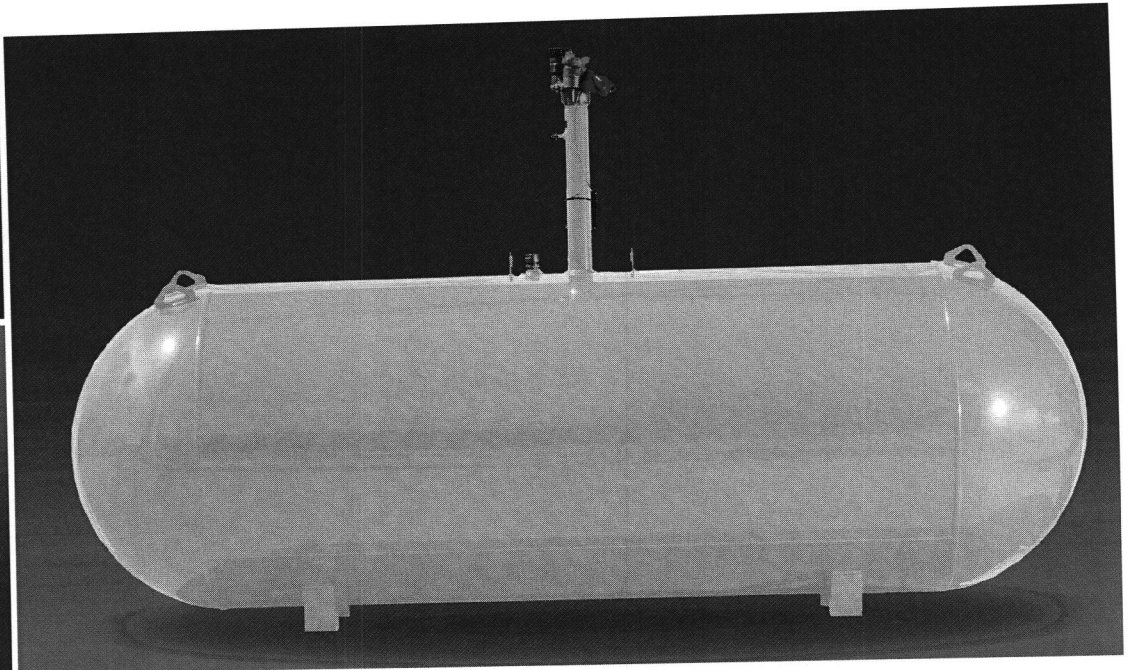

PRESSURE VESSEL CODES & REGISTRATION

- Designed and constructed in accordance with the ASME Section VIII, Division 1 Code
- Registered with the National Board of Boiler & Pressure Vessels Inspectors
- Complies with NFPA 58
- Conforms to specifications set forth by the Railroad Commission of Texas

PAINT SPECIFICATIONS

- Epoxy powder paint for maximum rust protection
- Tanks painted gray
- Ready to bury durable epoxy powder coating†

SHROUD FEATURES (500 & 1,000 gallon)

- Durable construction
- Large opening for easy filling and maintenance
- Recessed markers to indicate proper burial depth
- Permanent hole for mounting location flag
- Access on sides for flexible riser connection
- New shroud available for 500 gallon and 1,000 gallon UG tanks, shroud dimensions:
 - * Shroud for long riser 32 3/16" X 26 5/16"
 - * Shroud for short riser 19 3/8" X 26 5/16"

VESSEL FEATURES

- Tanks fully fitted with RegO valves and Rochester liquid level gauges
- Container pressure rated at 250 PSI @ 400°F
- Vacuum purged
- Duplicate data plate is zip tied on the riser pipe below the anode bolt connection for convenience
- Product is offered with 14" short or 28" tall risers
- Anode bolt connection located under the dome
- Short or tall plastic shroud assemblies (w/lid) supplied accordingly
- #54 liquid level outage valve orifice

PROCESS CONTROL

All welded products are x-rayed and pressure tested @ 325 PSI per ASME Sec VIII, Div 1 requirements, followed by rigorous leak test inspections, both pre and post valving

STORAGE & DISTRIBUTION

Contact Propane Education & Research Council for additional resources and information at propane.com

Made With Pride



Made In the U.S.A.



UNDERGROUND PROPANE STORAGE TANKS 120 - 1000 Gallons

UNDERGROUND VESSEL DIMENSIONS & SPECIFICATIONS (All Vessel Dimensions are Approximate)

Part Number	Description	Water Capacity Gal/l	Outside Diameter In/mm	Head Type	Overall Length In/mm	Overall Riser Height In/mm		Leg Width In/mm	Leg Spacing In/mm	Weight Lbs/kg	Quantity	
						18" Riser	28" Riser				Full Load	Per Stack
68289	120 Gallon Underground LR Storage Tank	120 454.2	24" 609.6	Ellip	5' 8" 1727.2	- -	4' 7 13/16" 1417.6	10 1/8" 257.2	3' 0" 914.4	342 155.4	63	9
68269	120 Gallon Underground SR Storage Tank	120 454.2	24" 609.6	Ellip	5' 8" 1727.2	3' 9 1/4" 1149.4	- -	10 1/8" 257.2	3' 6" 914.4	329 149.2	72	9
68288	250 Gallon Underground LR Storage Tank	250 946.3	30" 762	Hemi	7' 10" 2387.6	- -	5' 1 9/16" 1563.7	12 3/4" 323.9	3' 6" 1066.8	494 224.1	42	7
68271	250 Gallon Underground SR Storage Tank	250 946.3	30" 762	Hemi	7' 10" 2387.6	4' 3" 1295.4	- -	12 3/4" 323.9	3' 6" 1066.8	480 217.7	42	7
68273	320 Gallon Underground LR Storage Tank	320 1211.3	30" 762	Hemi	9' 7" 2921	- -	5' 1 9/16" 1563.7	12 3/4" 323.9	4' 0 1/4" 1225.6	597 270.8	35	7
68285	320 Gallon Underground SR Storage Tank	320 1211.3	30" 762	Hemi	9' 7" 2921	4' 3" 1295.4	- -	12 3/4" 323.9	4' 0 1/4" 1225.6	593 269	35	7
68275	500 Gallon Underground LR Storage Tank	500 1892.7	37.5" 952.5	Hemi	9' 10" 2997.2	- -	5' 9 3/8" 1762.1	15" 381	5' 0" 1524	953 432.3	25	5
68286	500 Gallon Underground SR Storage Tank	500 1892.7	37.5" 952.5	Hemi	9' 10" 2997.2	4' 8 1/2" 1435.1	- -	15" 381	5' 0" 1524	949 430.5	25	5
68277	1000 Gallon Underground LR Storage Tank	1000 3785.4	41" 1041.4	Hemi	15' 11" 4851.4	- -	6' 3/16" 1849.4	16 1/4" 412.8	9' 0" 2743.2	1812 821.9	12	4
68287	1000 Gallon Underground SR Storage Tank	1000 3785.4	41" 1041.4	Hemi	15' 11" 4851.4	5' 0" 1524	- -	16 1/4" 412.8	9' 0" 2743.2	1793 813.3	12	4

† Federal, state or local regulations may contain specific applicable requirements for protective coatings and cathodic protection. The purchaser and installer are responsible for compliance with such federal, state, local and NFPA industry regulations, including, but not limited to, proper purging prior to putting into service. Cathodic protection is required. Coating(s) must be continuous, uninterrupted and must comply with local, state or national codes or regulations.

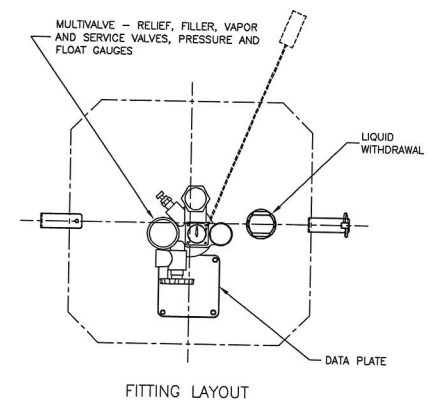
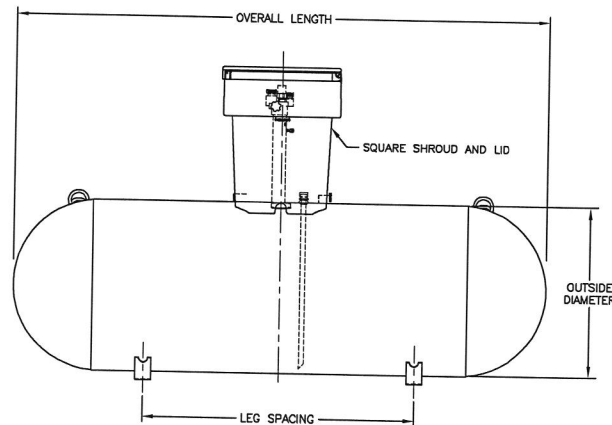
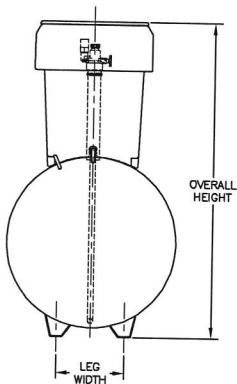

Rappaport, Ryan

From: Huskins, Thomas
Sent: Tuesday, December 2, 2025 10:11 AM
To: Harding, Derrick
Cc: Rappaport, Ryan
Subject: FW: Brickell Way - LP tank installs without permits - Thompson Gas (Brickell Property Subdivision)

Look at these permits. Who is the builder (assuming this is new construction), contact builder and we will suspend all trade inspections until issues are resolved I applicable.
LMK.

Tom

From: Rappaport, Ryan <RRappaport@howardcountymd.gov>
Sent: Tuesday, December 2, 2025 9:43 AM
To: Michelle Clancy <michelle@appliedandapproved.com>
Cc: Huskins, Thomas <thuskins@howardcountymd.gov>; Williams, Jeffrey <jewilliams@howardcountymd.gov>; tfaris@elmstreetdev.com; msroun@nvrinc.com; Wolf, Kevin <KWolf@howardcountymd.gov>; Page, Shepsura <spage@howardcountymd.gov>; Burns, Matthew <mburns@howardcountymd.gov>; 'brohrer@thompsongas.com' <brohrer@thompsongas.com>; rhinkleman@thompsongas.com
Subject: RE: Brickell Way - LP tank installs without permits - Thompson Gas (Brickell Property Subdivision)

Michelle, I completed site inspections for the 8 bp's that were submitted for lp tank installs at the properties in this subdivision. So far, I'm finding some issues with ones that have already installed without a permit.

B25005272 – 1730 Brickell Way – this is one that's already been installed and if the scale is right on the plan you submitted with the building permit, it's less than 50' away from the well box on the neighboring property – please follow up on this one with either having them dig it up and move it, check the scale on the plan (make sure it's right) or fill out the County waiver request form.

B25005266 – 1711 Brickell Way – Thompson Gas was onsite yesterday installing the lp tank in a different location than you have it on the submitted plan – provide a revised plan for review as soon as possible

B25005267 – 1719 Brickell Way – the plan isn't showing the onsite septic system for the property and the proposed location for the lp tank on the plan you submitted is in close proximity to the septic tanks. Please get the septic tanks and setback on the plan and resubmit.

B25005273 – 1727 Brickell Way – lp tank was installed as of 12/1/2025 prior to permit release.

B25005271 – 1731 Brickell Way – lp tank was installed as of 12/1/2025 prior to permit release.

1734, 1735 and 1739 Brickell Way – lp tanks not installed yet and the bp is still under review.

If you have any questions or concerns, please don't hesitate to reach out.

Ryan

From: Michelle Clancy <michelle@appliedandapproved.com>
Sent: Monday, December 1, 2025 2:32 PM
To: Rappaport, Ryan <RRappaport@howardcountymd.gov>
Subject: Re: Brickell Way

WARNING!!!

This email originated from someone outside of Howard County
DO NOT CLICK LINKS OR OPEN ATTACHMENTS
unless you recognize the sender and know for sure that the content is safe

Oh thanks!

I had no idea they started with out them...

Please keep me posted in what's next.

Thank you in advance for all your help.

Sent from my iPhone

Please excuse any spelling, grammar, wording & any others errors that I have made or this auto correct thing decided to make.

On Dec 1, 2025, at 2:25 PM, Rappaport, Ryan <RRappaport@howardcountymd.gov> wrote:

Michelle, I was out to the site of the subdivision today. Thompson Gas was onsite installing the propane tanks before the release of the permit. Most of these have already been installed. I'll need to speak with my supervisor and DILP before anything else is done on these reviews.

Ryan

Get Outlook for iOS

From: Michelle Clancy <michelle@appliedandapproved.com>
Sent: Monday, December 1, 2025 1:09:23 PM
To: Rappaport, Ryan <RRappaport@howardcountymd.gov>
Subject: Brickell Way

WARNING!!!

This email originated from someone outside of Howard County
DO NOT CLICK LINKS OR OPEN ATTACHMENTS
unless you recognize the sender and know for sure that the content is safe

Good Afternoon-

I hope you had a great Thanksgiving!

If you would be able to look at these permits sooner rather than later, that would be an immense help.

B25005273

B25005272

B25005271

B25005270

B25005269

B25005268

B25005267

B25005266

Thank you!!!

Michelle Clancy
Applied & Approved Permit Service
appliedandapproved.com
443-610-7514

approved
5br
Jw
8/21/25

Record Detail * (This section is required.)

Permit Type Building/Residential/New/SFD
 Permit Number B25002519
 Opened Date 06/25/2025

Description of Work
 SFD/MODEL "SANTORINI", 2 STORY, Full Basement, Basement = Partially Finished, 9R, 6FB, 1HB, 0FP, 1 & 2 Car Garage, 5BR, Front Porch, ENERGY METHOD = Performance Method, null.

shared (Lot 6)

[check spelling](#)

Address * (This section is required.)

Street # 1735
 Street Name BRICKELL
 Street Type WAY

Unit Type --Select--
 Unit #
 X Coordinate
 Y Coordinate

City MARRIOTTSVILLE
 State MD
 Zip Code 21104
 Primary Yes

Parcel * (This section is required.)

GIS ID *	Parcel	Parcel Area	Land Value	Improved Value	Exemption Value	Plan Area
11061834	0274	0	0	0	0	RURAL

Legal Description

[check spelling](#)

Block	Lot	Census Tract	Council Dist	Inspection Dist	Supervisor Dist	Map #	DAP Zone
1	6	603000	5				

Plan Area
 State Tax Id
 Subdivision Name
 Brickell Property

Section
 Area
 Tax Map
 10

Grid 10-1
 Zoning District RR-DEO
 ADC Map 4694-A6

SDP No.
 Final Plan No. ECP-19-021
 WP File No.

Record Plat No. 26102-2610
 WS Contract No.
 FDP No.
 Primary Yes

Owner Occupied Yes No
 Year Built
 Historic District Yes No

Historic District Registry No.
 Stat Area 3-01
 Flood Plain Yes No

Building No

Owner (This section is not required.)

Name *
 NVR, II

Address Line 1
 11700 PLAZA AMERICAN DRIVE, SUITE #500

Address Line 2

Address Line 3

Mail City RESTON
Mail State VA
Mail Zip Code 20190

Phone 703-956-4000
Primary Yes
E-mail

mbertoni@nvrinc.com
Cell Number
4103795956

Fax Number

Professionals (This section is not required.)

License # * 56
License Type * Home Bldr
Primary Yes

Business Name NVR, INC. T/A NV HOMES AND RYAN HOMES

First Name Matt Middle Name Last Name Bertoni

Address Line 1 11700 PLAZA AMERICA DRIVE, SUITE #500
Address Line 2

City RESTON State VA ZIP Code 20190

Phone 1 7039564000 Phone 2 4103795956 Fax

E-mail mbertoni@nvrinc.com

Applicant (This section is not required.)

Search As Owner As Lic. Prof As Contact

Type * Applicant
Relationship Applicant
Primary No

First Name JAMES MI J Last Name KERWIN

Full Name JAMES J KERWIN

Organization Name DECATUR BUILDING SERVICES

Street Address PO Box 552
Address Line 2

City WOODBINE State MD Zip Code 21797

Phone 4433097792 Cell 4433097792 Fax

E-mail jim@decaturbuildingservices.com

Contact (This section is not required.)

Search As Owner As Lic. Prof As Contact

Type Contact
Relationship Licensed Professional
Primary Yes

First Name Matt MI Last Name Bertoni

Full Name

Organization Name NVR, INC. T/A NV HOMES

Street Address 7080 Samuel Morse Drive
Address Line 2

City Columbia State MD Zip Code 21046

Phone 4433097792 Cell 4103795956 Fax

E-mail mbertoni@nvrinc.com

Addtl Info

Est Construction Cost * 230000
Construction Type --Select--

Housing Units * 0

Number of Buildings * 0

Public Owned No

BUILDING INFORMATION

BUILDING INFORMATION

Capital Project-No Fee * Capital Project # Fee Exempt * Roadside Tree Project Permit Roadside Tree Project Permit #

Yes No
 Yes No
 No of Stories * 2 (Text)
 Bedrooms * 5 (Number)
 W&S Fees Paid Yes No
 1st Floor Width 68 FT (Number) 54
 Building Construction Type Conventional
 Location Survey Approval Date [calendar icon]
 U&O Issued On [calendar icon]

Condominium Yes No
 Foundation * Full Basement
 Porch Deck Front Porch
 Water Supply * Private
 1st Floor Depth FT (Number) 54
 Road Frontage County
 U & O Comments

Existing Use (Text) Vacant Lot
 Basement Partially Finished
 No of Fireplaces * 0 (Number)
 Sewage Disposal * Private
 2nd Floor Width FT (Number) 54
 Footings
 Road Frontage County
 U & O Comments

Yes No
 Yes No
 Model * SFD/MODEL "SANTORINI"
 No of Rooms * 9 (Text)
 Type of Fireplace --Select--
 Utilities * Gas & Electric
 Heating System * Electric & Propane Gas
 Energy Code Performance Method
 Full Baths * 6 (Number)
 Half Baths * 1 (Number)
 Basement Width FT (Number) 54
 Basement Depth FT (Number) 54
 Foundation Measurement (Text)
 Additional Description Info

Oth 18 (Number)
 Sprinkler S NFPA #13
 Height FT
 Walls FT
 Expiration Date 12/28/2025 [calendar icon]

[check spelling](#) [check spelling](#)

GRADING INFORMATION

Grading Permit No * G (Text)
 Grading Certification Required Yes No
 Grading Certification Received in DILP On [calendar icon]
 Grading Certification
 Grading Certification Comments
 Seasonal Surety Comments

[check spelling](#)

[check spelling](#)

Seasonal Grading Surety Depositor (Text)
 Driveway Apron Surety Depositor (Text)
 Stormwater Surety Depositor

GREEN NEIGHBORHOOD INFORMATION

Check List Points Goal (Text)
 Check List Points Achieved (Text)
 Date of Certification [calendar icon]

PRIVATE ON LOT SWM FACILITIES

Green Roofs A1 Yes No
 Permeable Pavements A2 Yes No
 Reinforced Turf A3 Yes No
 Disconnection of Rooftop Runoff N1 (Number)
 Disconnection of Non Rooftop Runoff N2 Yes No
 Sheetflow to Conservation Areas N3 Yes No
 Rainwater Harvesting M1 (Number)
 Submerged Gravel Wetlands M2 (Number)
 Landscape Infiltration M3 (Number)
 Infiltration Berms M4 (Number)
 Dry Wells M5 (Number) 1
 Micro Bioretention M6 (Number)
 Rain Gardens M7 (Number)
 Swales M8 (Number)
 Enhanced Filters M9 (Number)

Submit Cancel

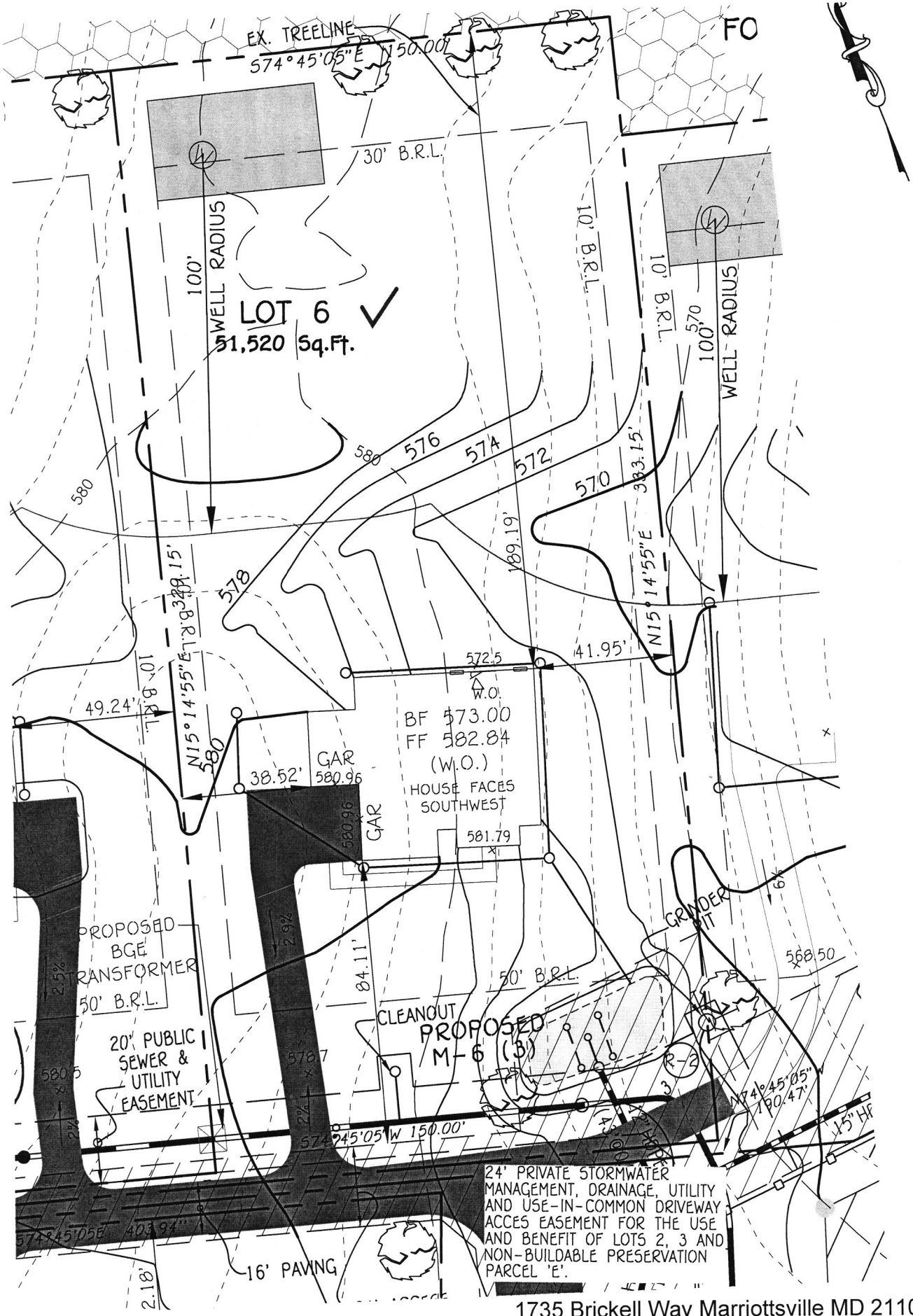

1735 Brickell Way Marriottsville MD 21104

WELL CERTIFICATION

THE EXISTING WELL TAG NO. HO-22-0103, HAS BEEN FIELD LOCATED AND IS ACCURATELY SHOWN.

BRICKELL PROPERTY
 TAX MAP: 10, GRID: 1,
 PARCEL: 274, ZONED: RR-DEO

PERMIT SITE PLAN
LOT 6